

**GENERAL PURPOSE
AND
GENERAL PURPOSE
SCREEN-TYPE
SPARK ARRESTERS**

ACERBIS

ACERBIS

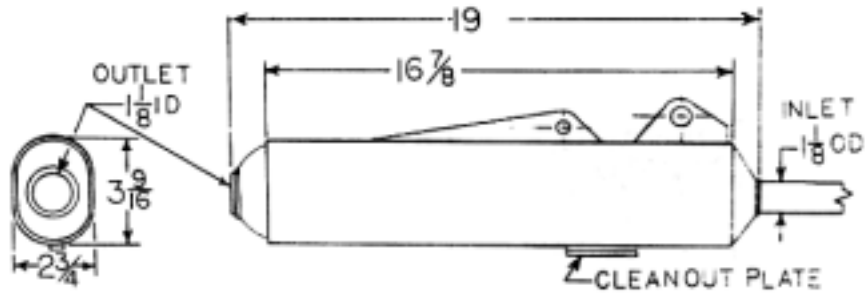

035 MFS-2

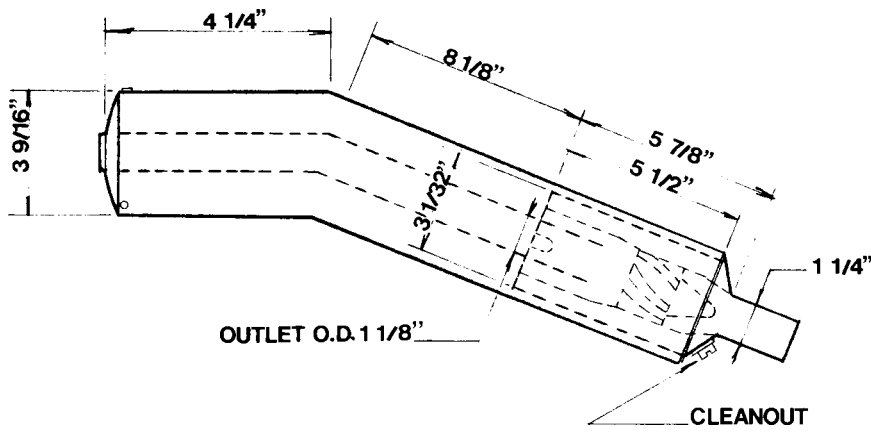

035 MFS-5

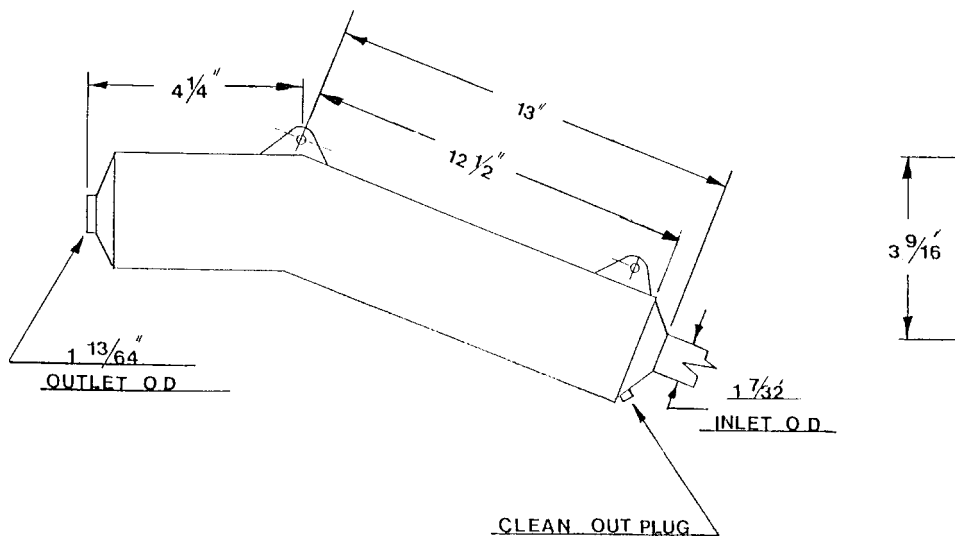

035 MFS-6

ADVANCED CAR SPECIALTIES

ADVANCED CAR SPECIALTIES

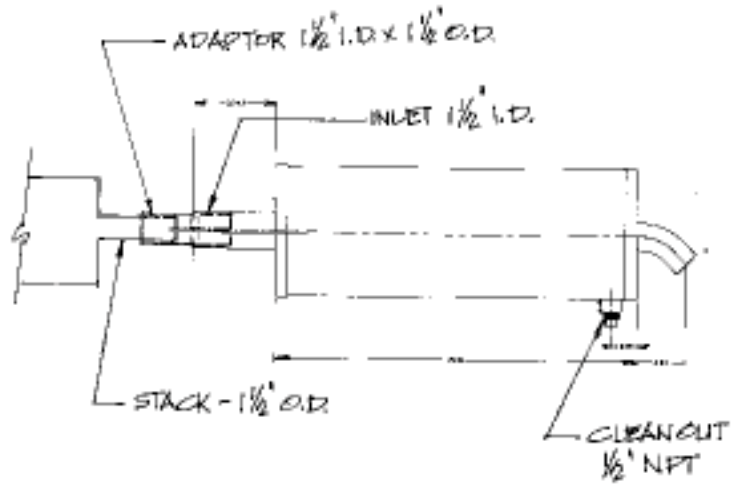

D1-508-183-03

AIR-MAZE

AIR-MAZE

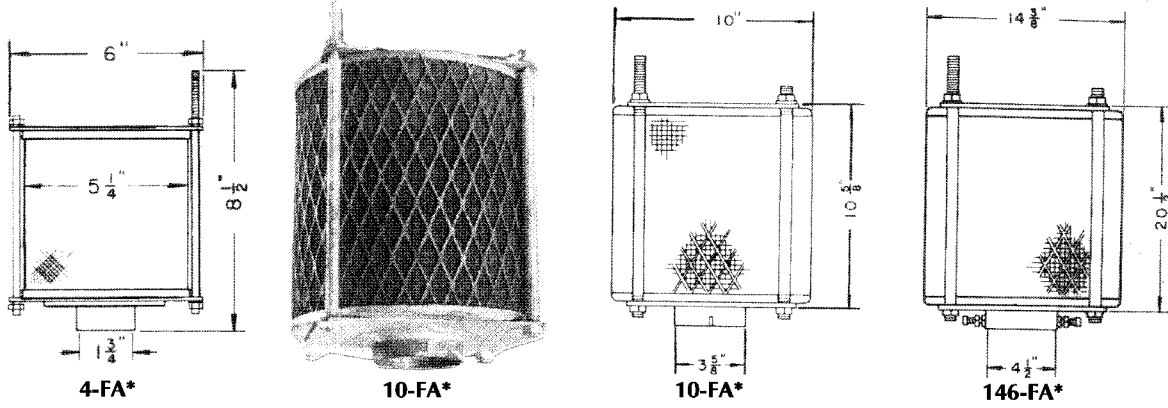

*The model designation indicates a minimum and maximum inlet size. Several inlet sizes are available.

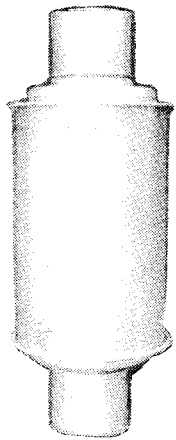

C19035

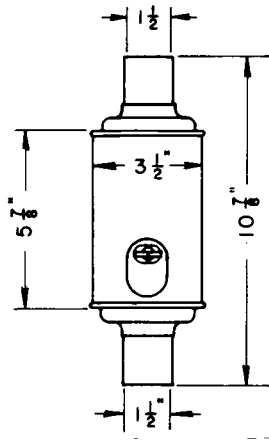

C19035-3

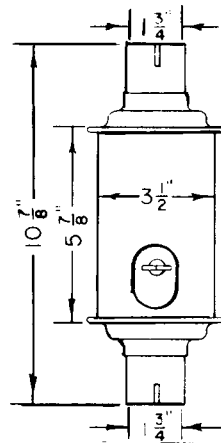

C19035-4

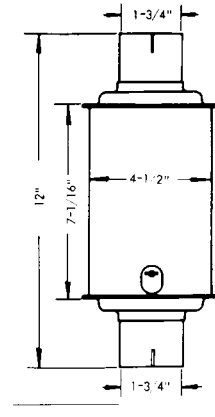

C19035-5

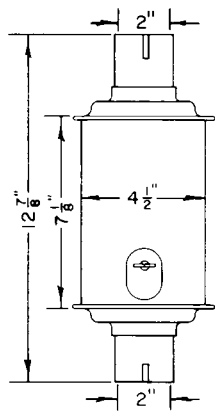

C19035-6

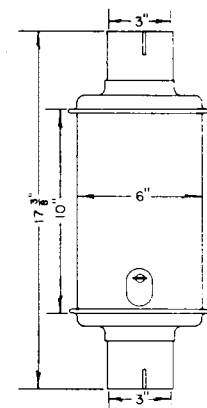

C19035-7 & 8

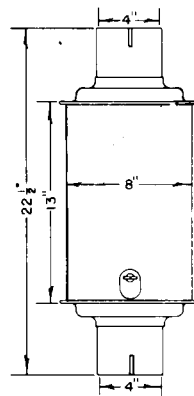

C19035-9 & 10

Model C19035-7 has 2 1/2" inlet and outlet dimensions identical. Likewise Model C19035-9 has 3 1/2" inlet and outlet dimensions.

ANSWER, J&R

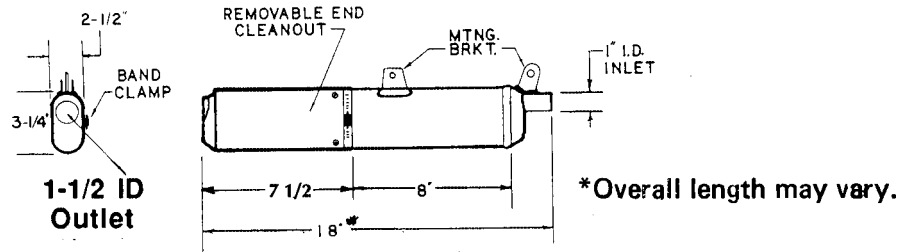

AP 650 C

- For Answer, J&R; AP-500D See Husqvarna-Krizman KS-500D
- For Answer, J&R; AP-650 See J&R Krizman KS-650
- For Answer, J&R; AP-650A See J&R Krizman KS-650A
- For Answer, J&R; AP-650C Approved as J&R Krizman KS-650C in an oval muffler
- For Answer, J&R; AP-650-0 See J&R Krizman KS-650-0
- For Answer, J&R; SA-PRO2 See J&R Krizman KS-650-0

NOTE: The removable end cleanout must be held in place by the band clamp. Welding the removable end cleanout in place is not permitted.

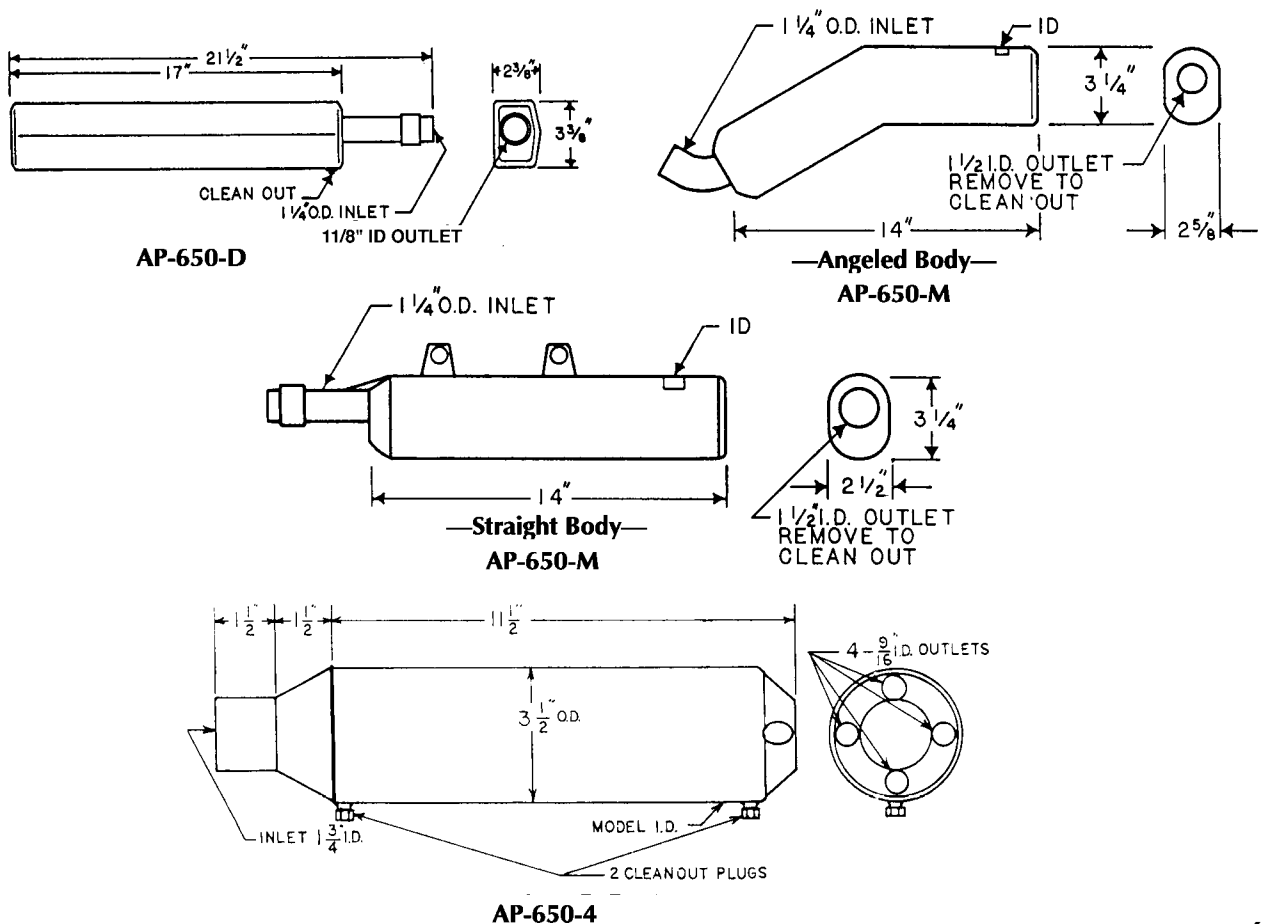

A.P. PARTS/BERKELEY BOMBARDIER/BOMBARDIER-KRIZMAN

A.P. PARTS

For A.P. Parts 83931893 see Donaldson FCM06-0037
 83931908 see Donaldson FCM06-5030
 83931910 see Donaldson FCM07-0068
 83931921 see Donaldson FCM07-0069
 83931933 see Donaldson FCM08-0024
 83933880 see Donaldson FCM09-0091
 83933892 see Donaldson FCM10-0016

BERKELEY

For Berkeley F70-01MC—see CEDCO No. 1
 For Berkeley F70-02MC—see CEDCO No. 2

BOMBARDIER/BOMBARDIER-KRIZMAN

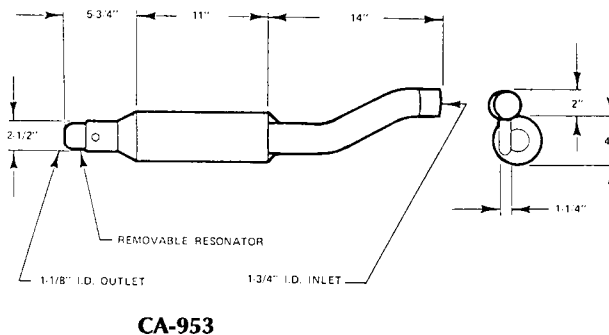
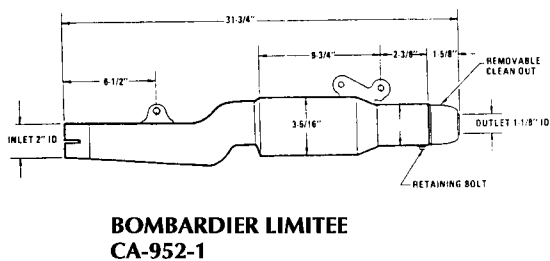
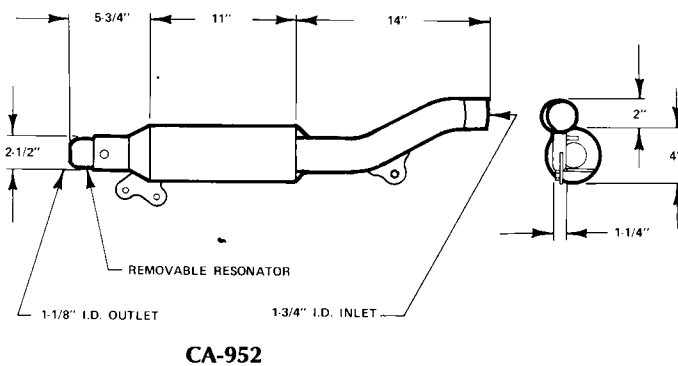
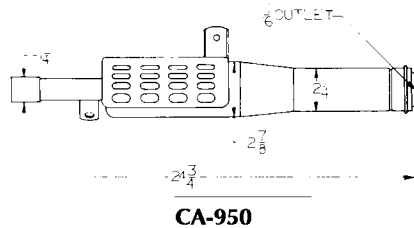
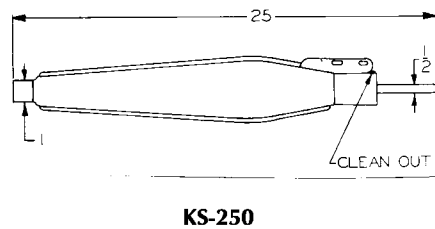
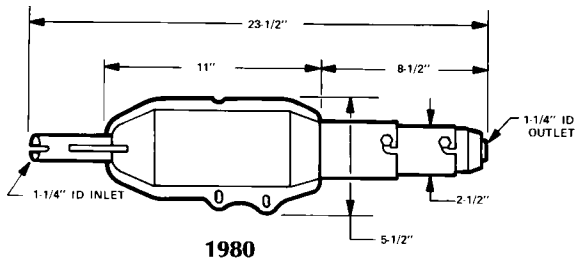

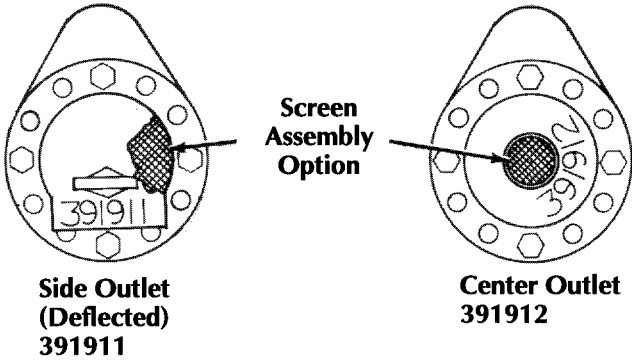

Model 391911 or 391912 depending on screen assembly option

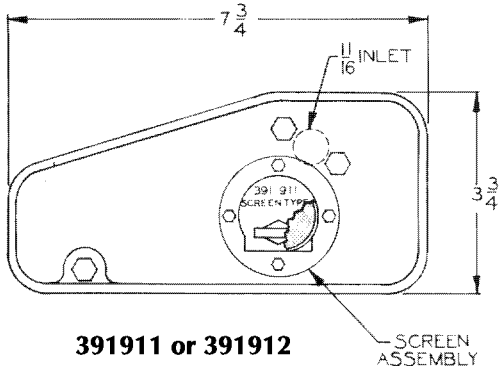

391911 or 391912

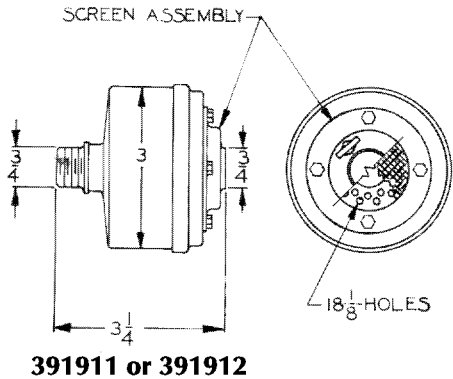

391911 or 391912

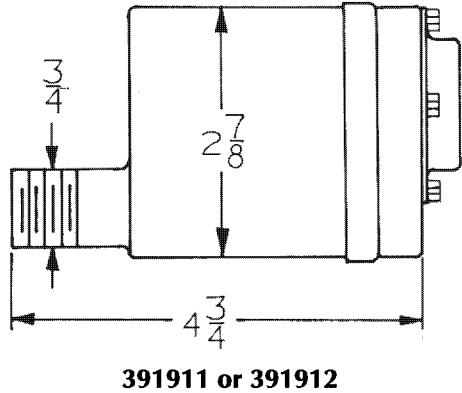

391911 or 391912

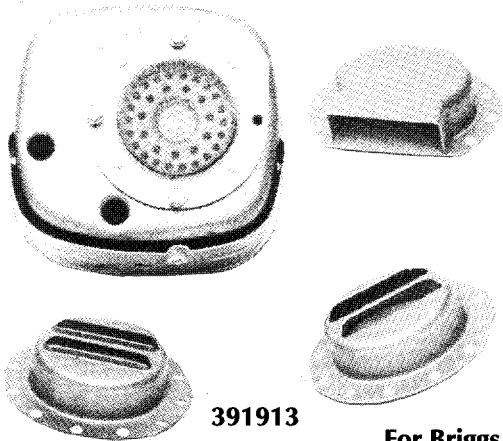

391913

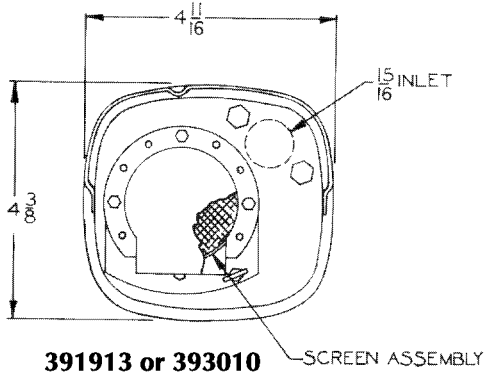

391913 or 393010

For Briggs & Stratton 391915 see Nelson T-14106

BRIGGS & STRATTON

BRIGGS & STRATTON

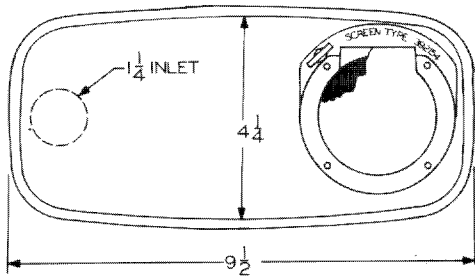

**"25" Super Lo-Tone Muffler 392101
392154 screen assembly**

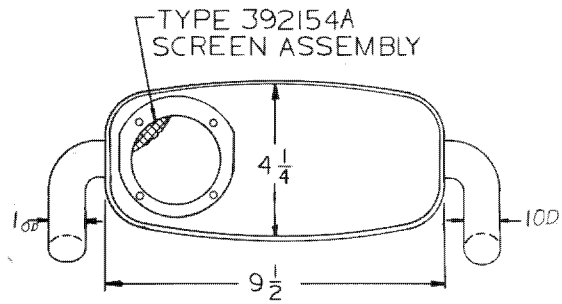

392154A

**Spark arrester screen for use on
Briggs & Stratton muffler nos.
392999 & 393281**

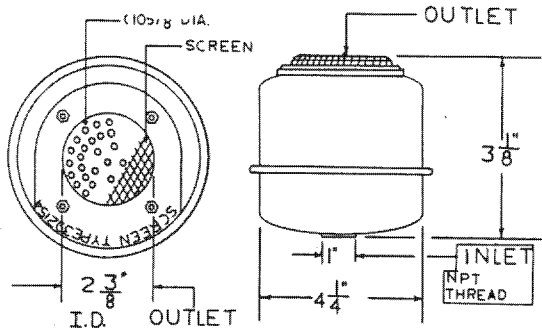

392989

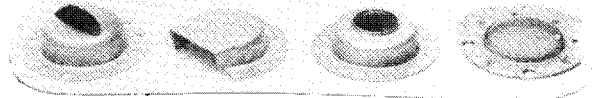
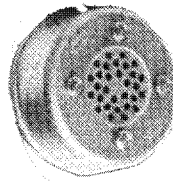

396800

**Briggs & Stratton Model 392154 screen assembly
on 392989 muffler body—note screen assembly
392154 & 392154A are interchangeable.
See drawing 391911 or 391912 on page 57.**

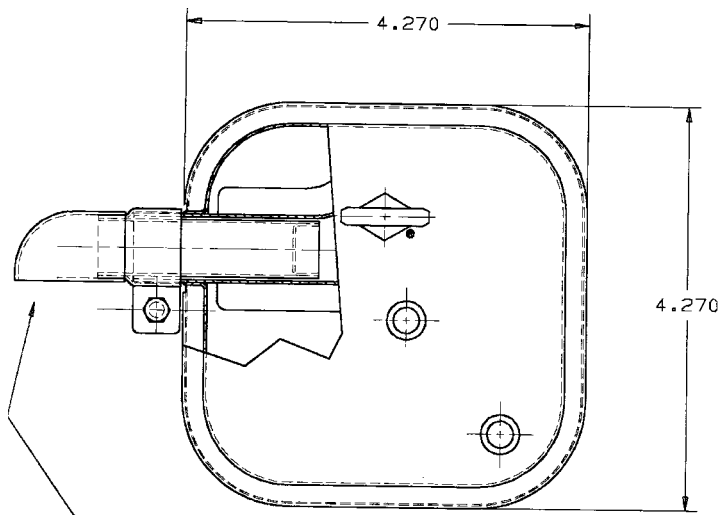

REMOVEABLE SPARK ARRESTER

494486

BRIGGS & STRATTON BURGESS-MANNING

BRIGGS & STRATTON (continued)

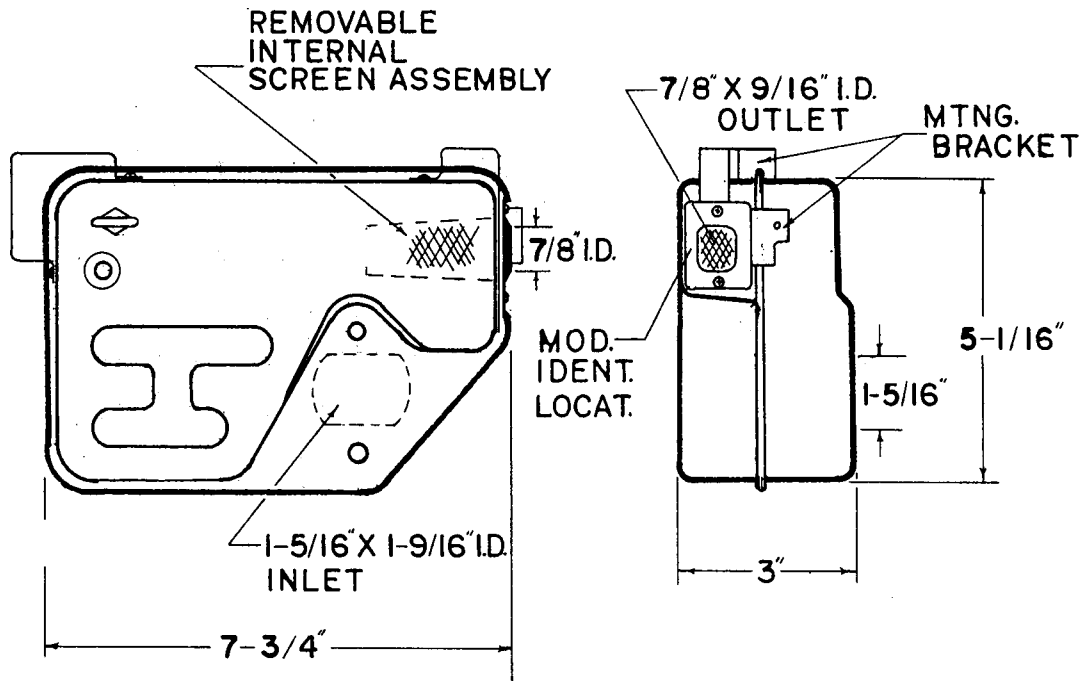

802502

BURGESS-MANNING

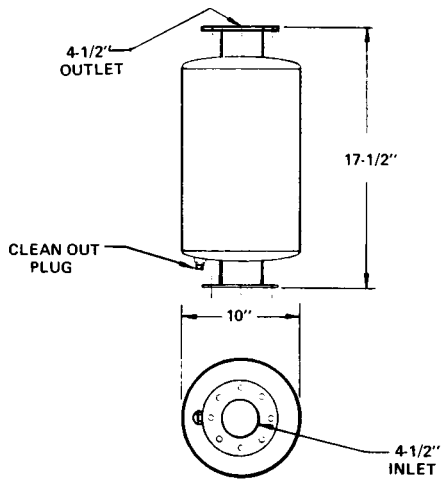

Burgess-Manning SAT-4

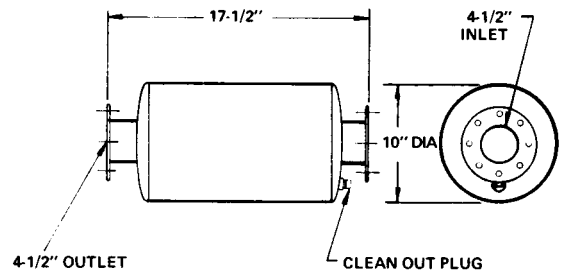

Burgess-Manning SAT-4

BURGESS-MANNING

BURGESS-MANNING (continued)

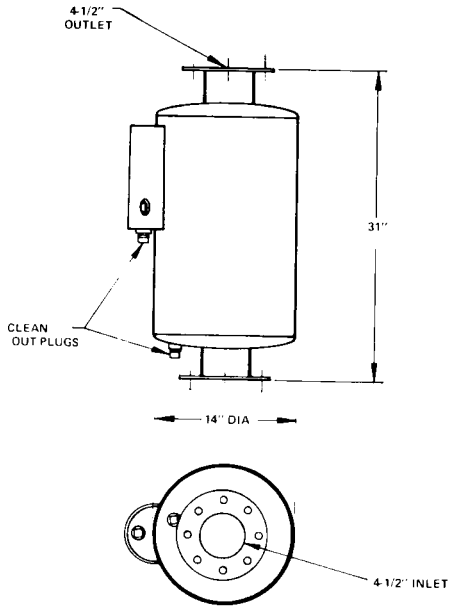

SDMC-4

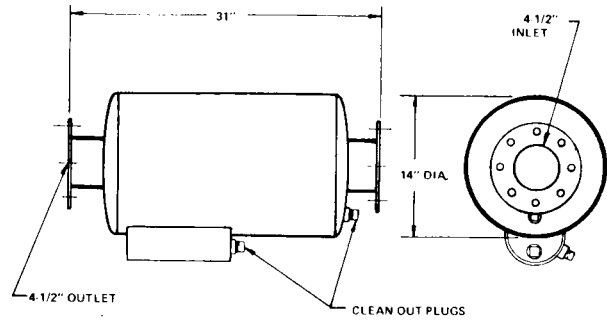

SDMC-4

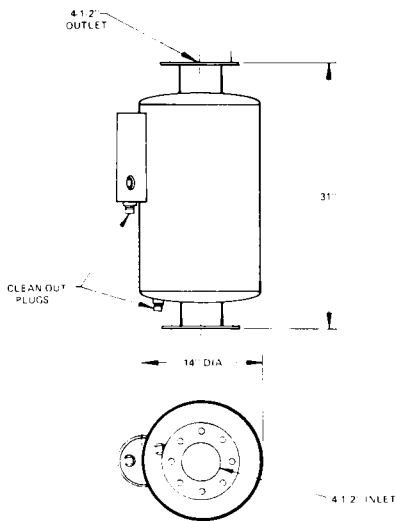

SDMC-LP-4

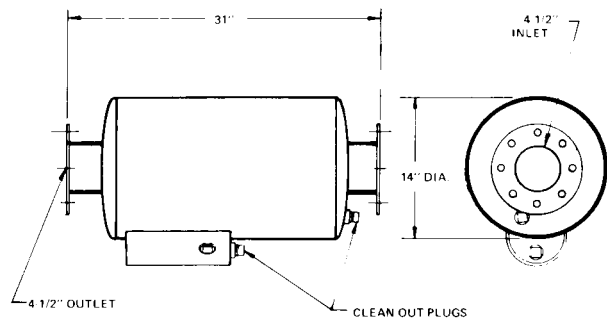

SDMC-LP-4

CAL TUBE

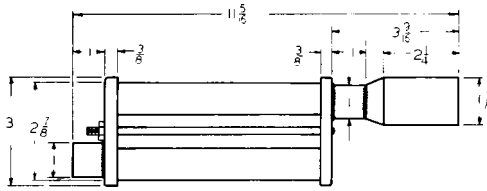

12853

CATERPILLAR

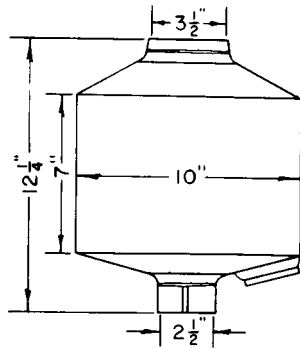

3B5498

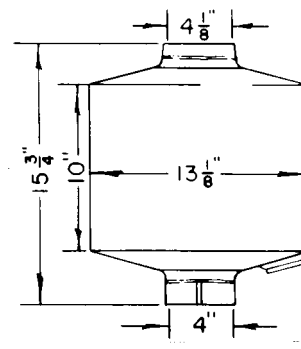

3B7964

For Caterpillar 3B7941—See Donaldson FCM07-0068
For Caterpillar 8N7074-1—See Donaldson FMM12-0303

CEDCO

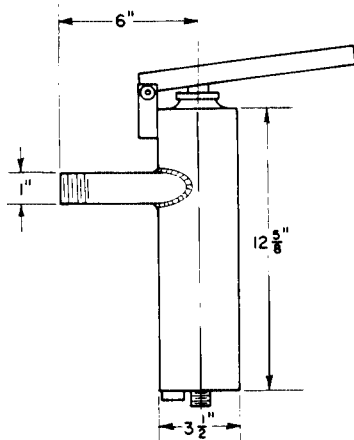

NO. 1

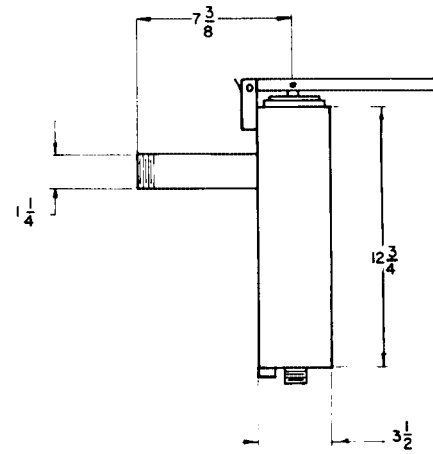

NO. 2

CHIYODA-KINZOKU CO., LTD. CLARK/CONE

CHIYODA-KINZOKU CO., LTD.

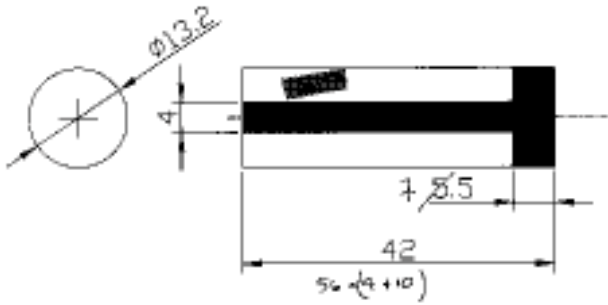

18077-2110 (KHI FC150V)

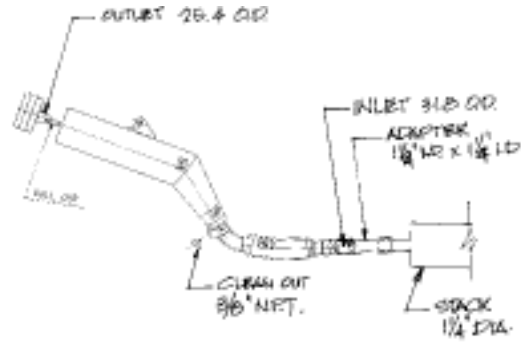

KL250G

CLARK

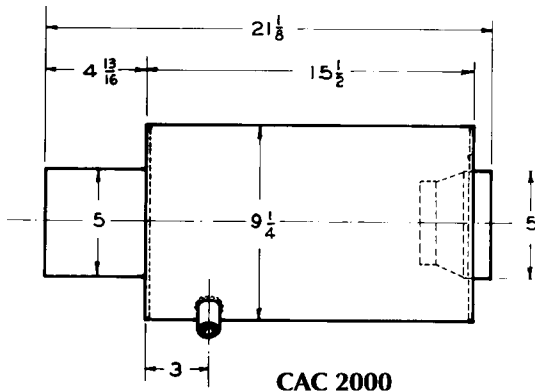

CAC 2000

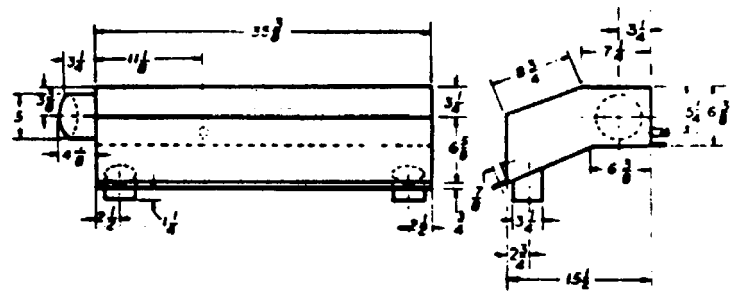

CAC 2000

Clark Equipment Company—Melrose Division
For Clark 6547049—See Nelson T-13473
For Clark 6551409—See Nelson T-14415
For Clark 6552340—See Nelson T-14907

CONE

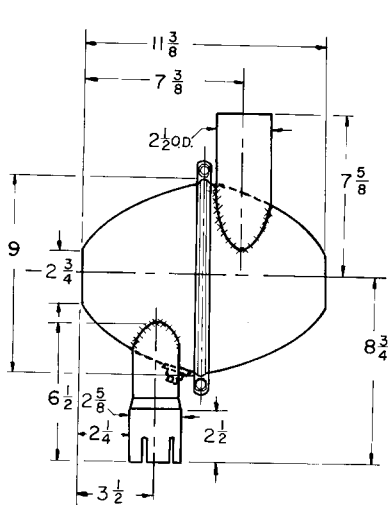

8-D

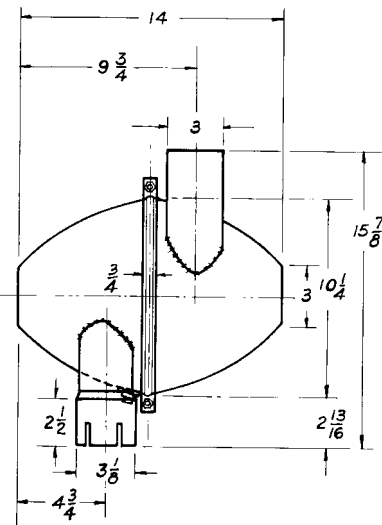

10-D

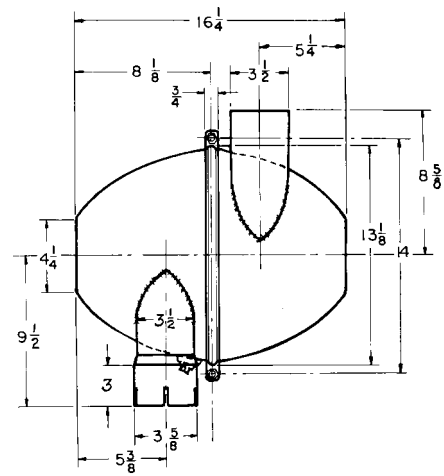

12D
Pulverization Type Spark Arrester
with an additional clean out plug

CONE (continued)

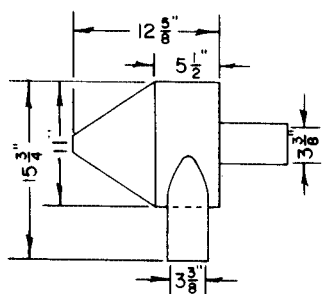

1100
Pulverization Type Spark Arrester

390 & 1500 Drawings not available

Known dimensions 390
Inlet Pipe Diam. 3"
Outlet Pipe Diam. 3"
Main Body Diam. 9"

Known Dimensions 1500
Inlet Pipe Diam. 4"
Outlet Pipe Diam. 4"
Main Body Diam. 15"

COOP

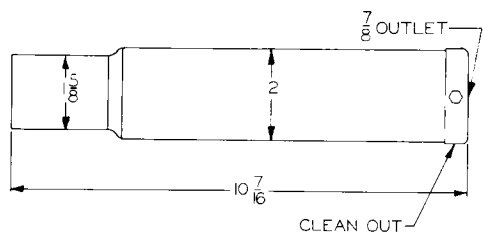

400A

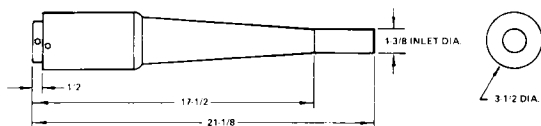

500A

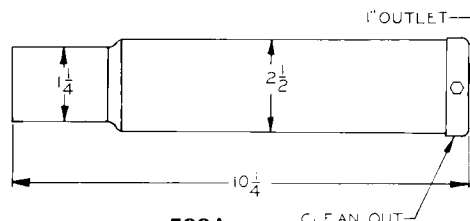

500A

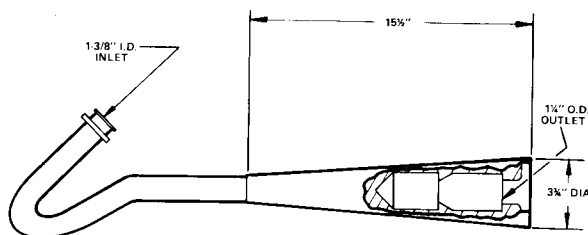

COOP 500A for LT 125

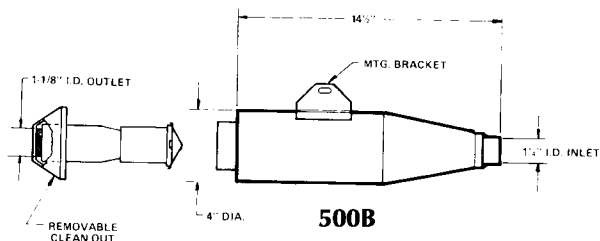

500B

CYCLE GEAR DAVIS

CYCLE GEAR

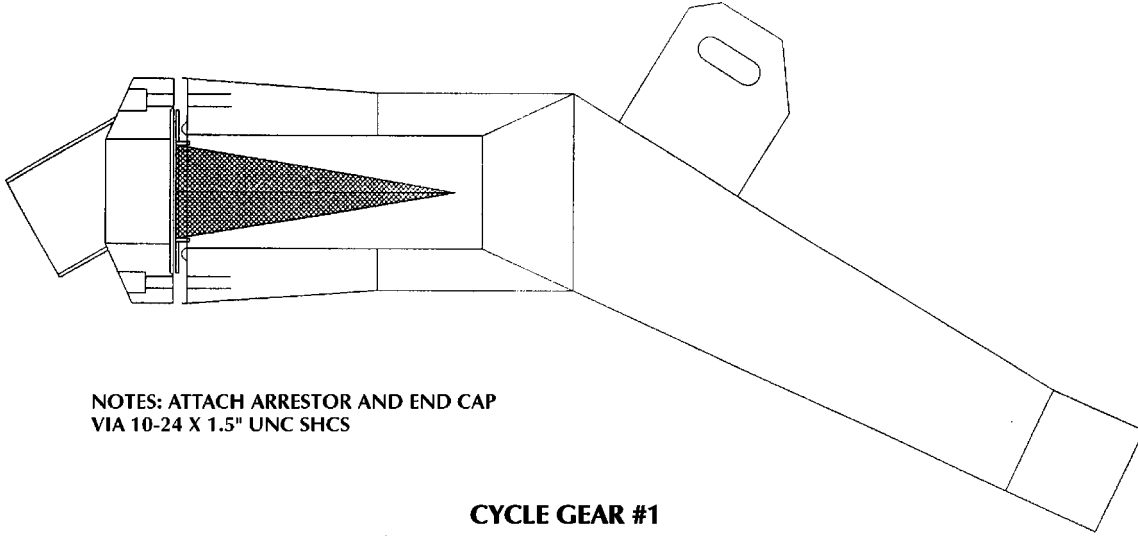

NOTES: ATTACH ARRESTOR AND END CAP
VIA 10-24 X 1.5" UNC SHCS

CYCLE GEAR #1

DAVIS

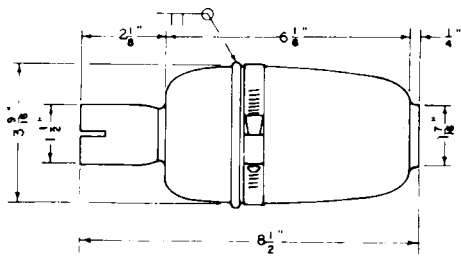

D-L 260

DOMETIC

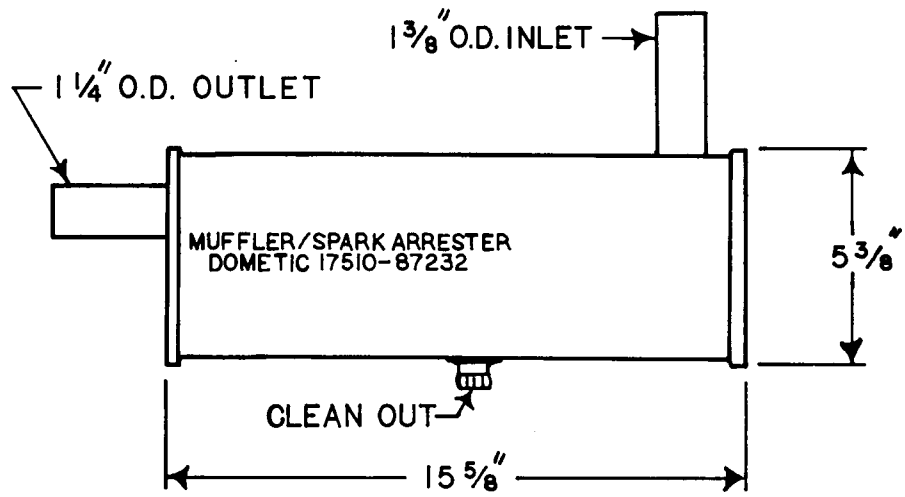

17510-87232

DONALDSON

DONALDSON

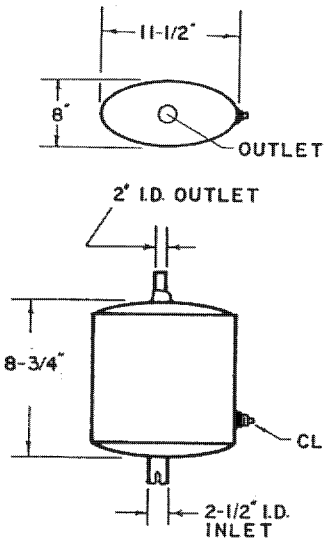

A184241

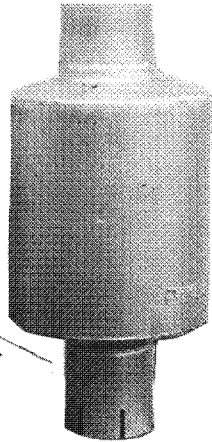

FCM0

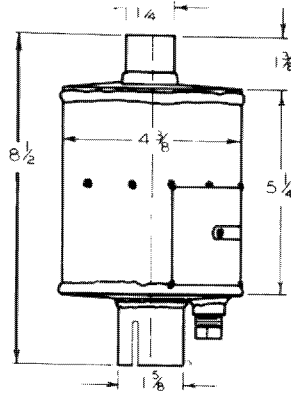

FCM04-5123

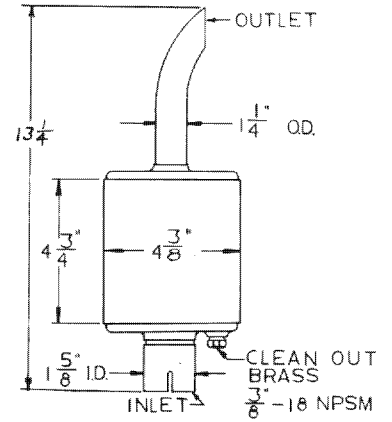

FCM04-5214

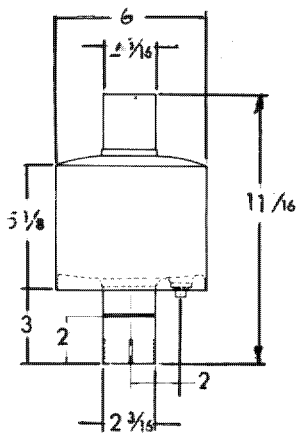

FCM06-0037

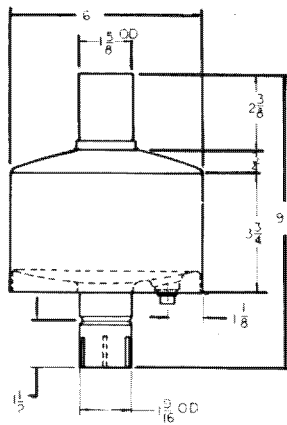

FCM06-0038

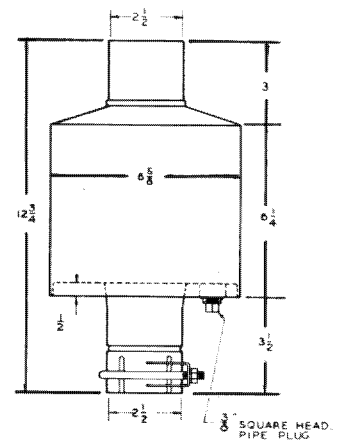

FCM06-5030

Note: Early models may carry a -1 at the end of number.

DONALDSON (continued)

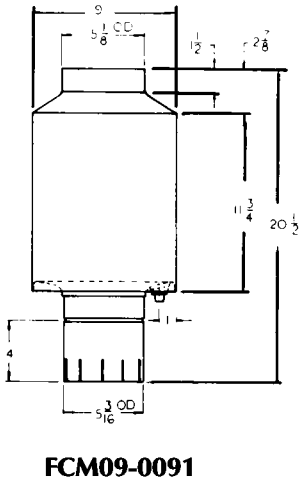
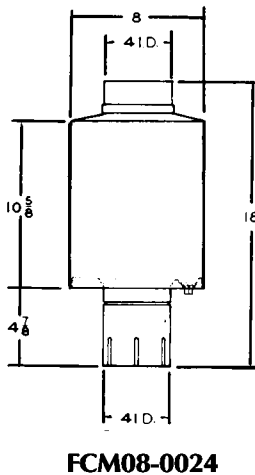
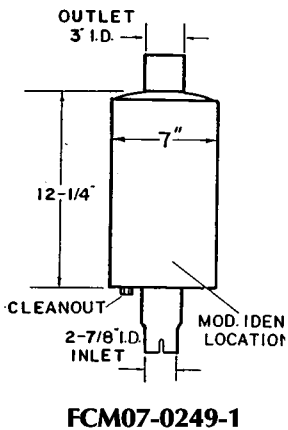
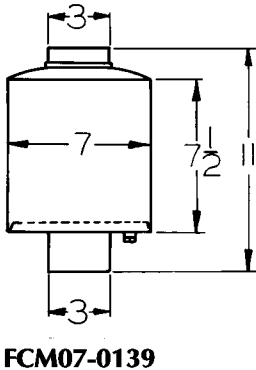
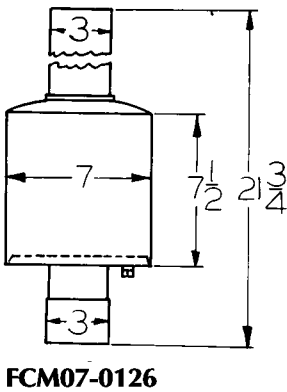
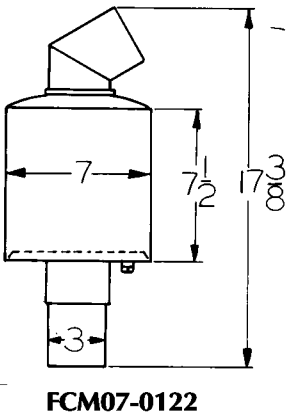
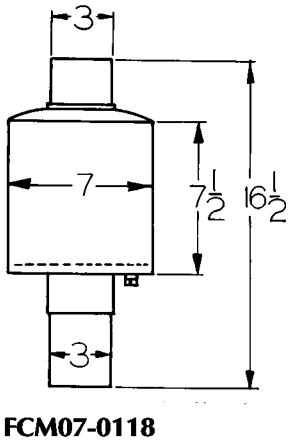
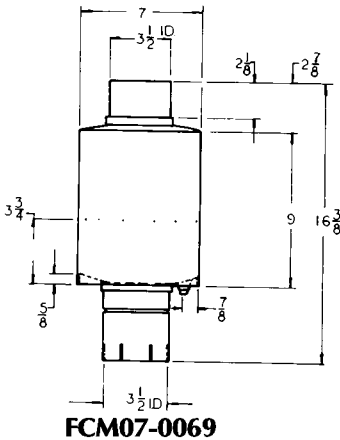
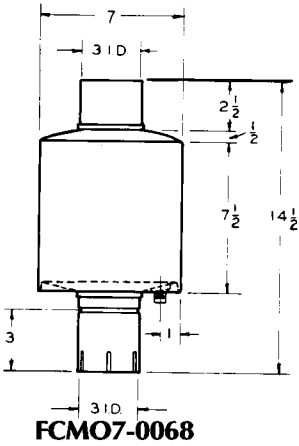

Note: Early models may carry a -1 at the end of number.

DONALDSON

DONALDSON (continued)

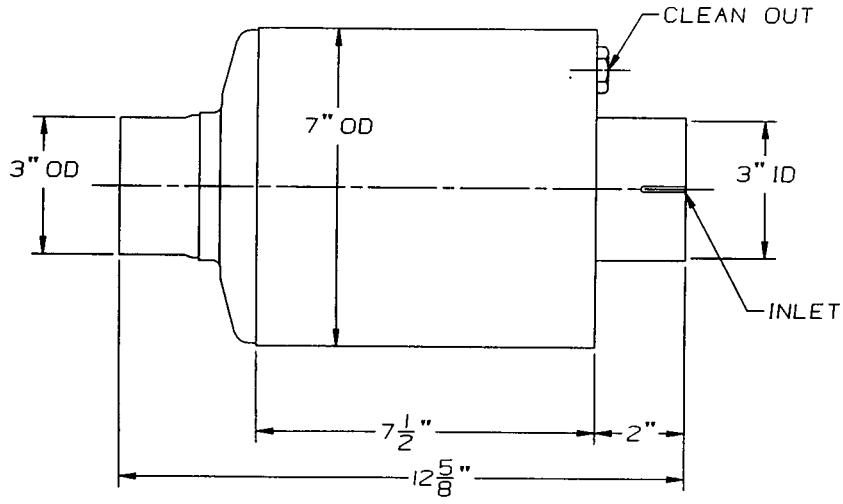

FCM070304

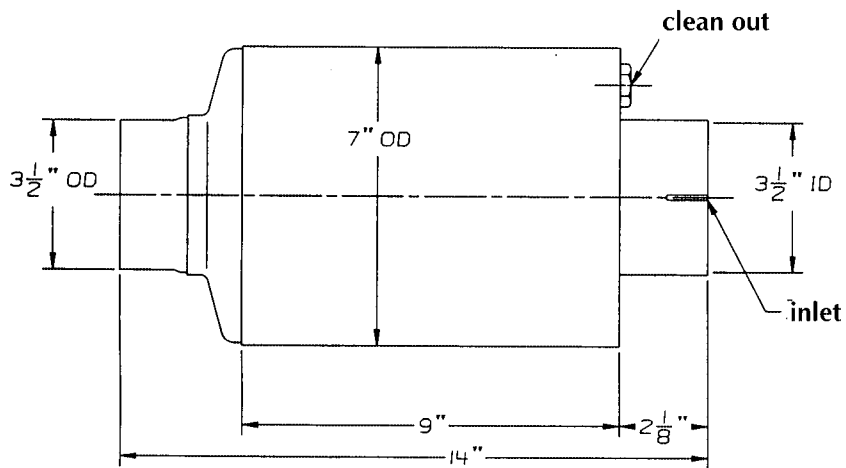

FCM070305

DONALDSON (continued)

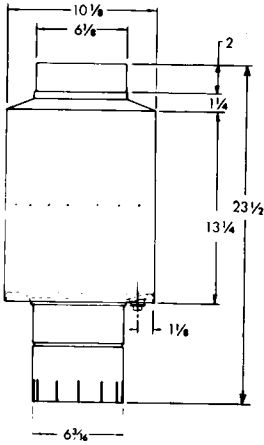

FCM10-0016

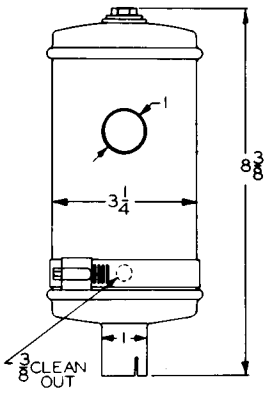

FMM03-2515

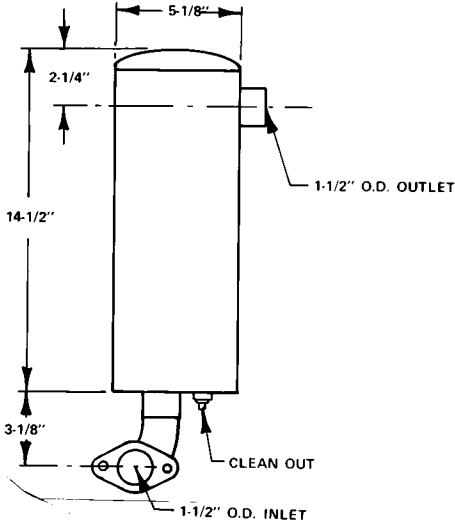

FMM05-0073

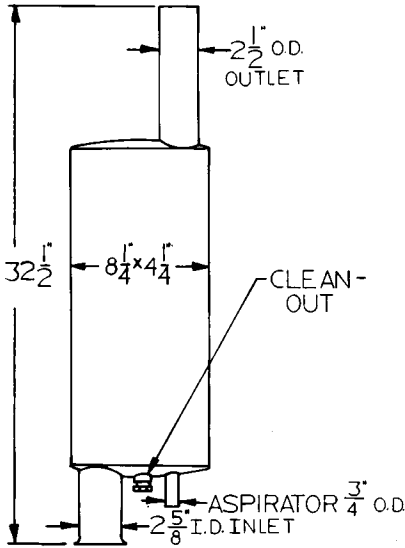

FMM06-0175

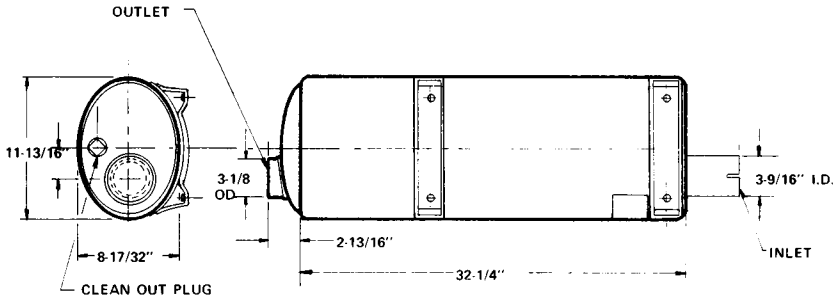

FMM09-0446

Note: Early Models may carry a-1 at the end of number

DONALDSON

DONALDSON (continued)

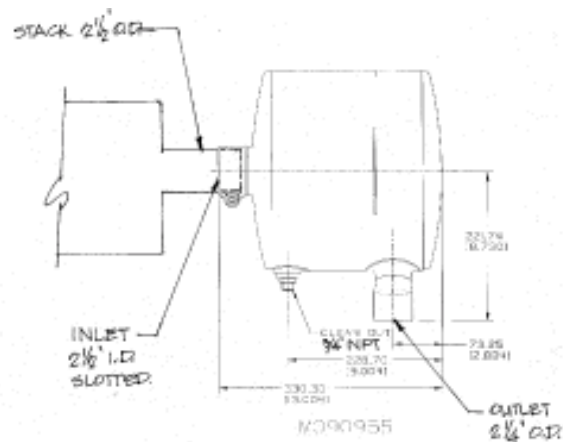
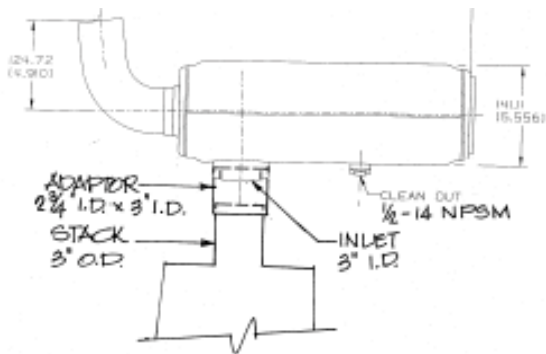
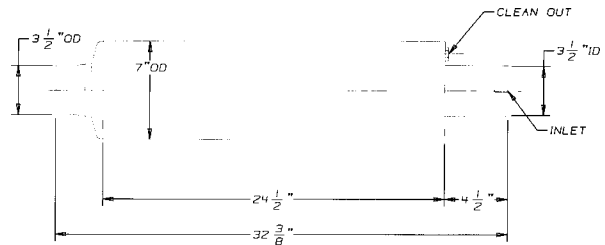
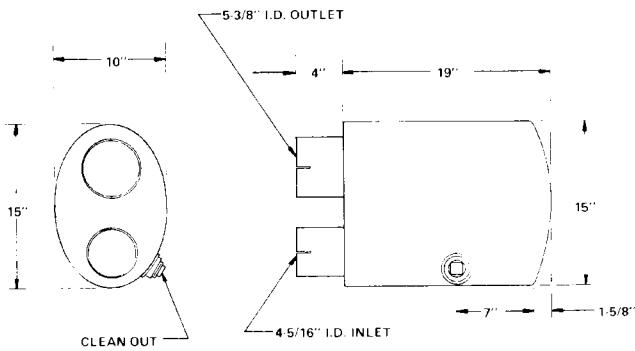
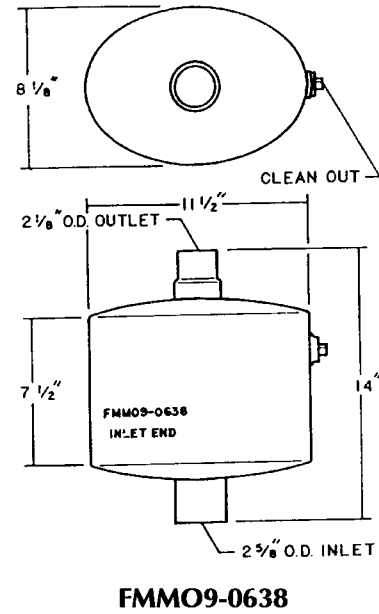
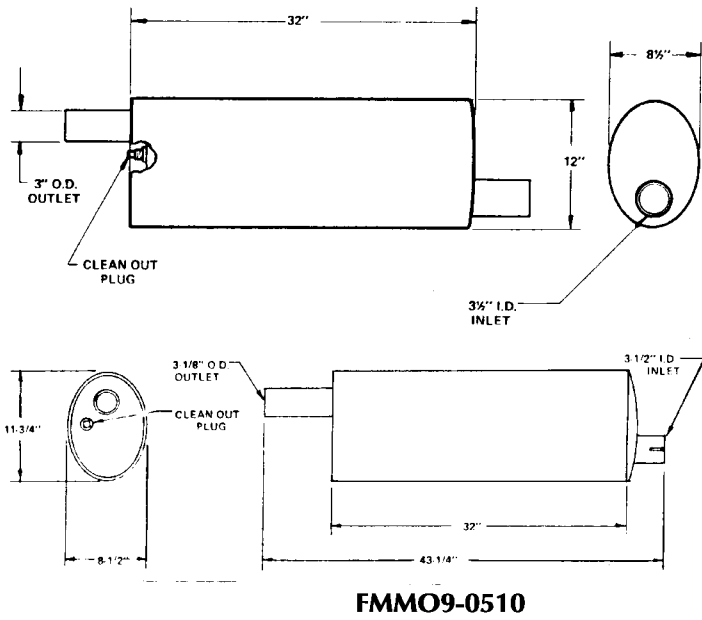

DONALDSON (continued)

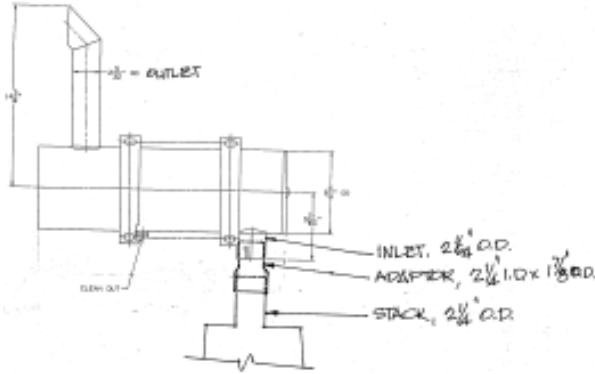

142-8811

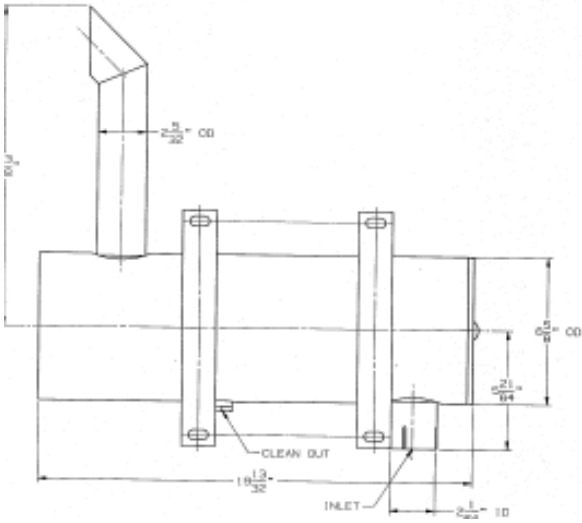

142-8845

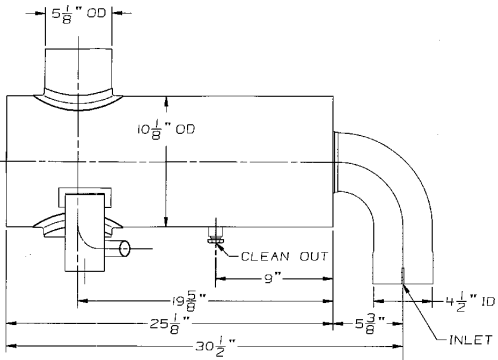
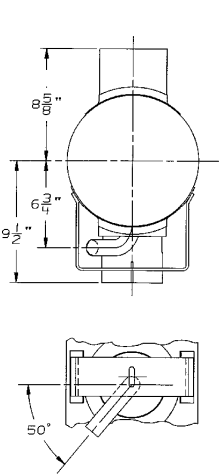

Donaldson 181590A1

181590A1

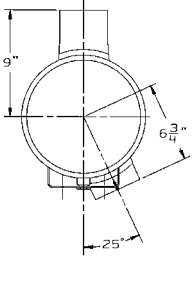

197297A1

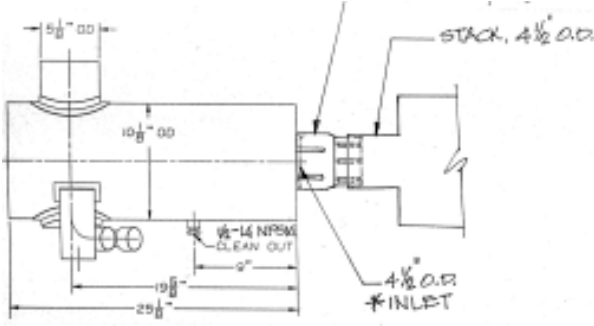
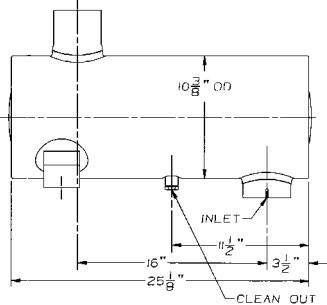

280811A1

DONALDSON

DONALDSON (continued)

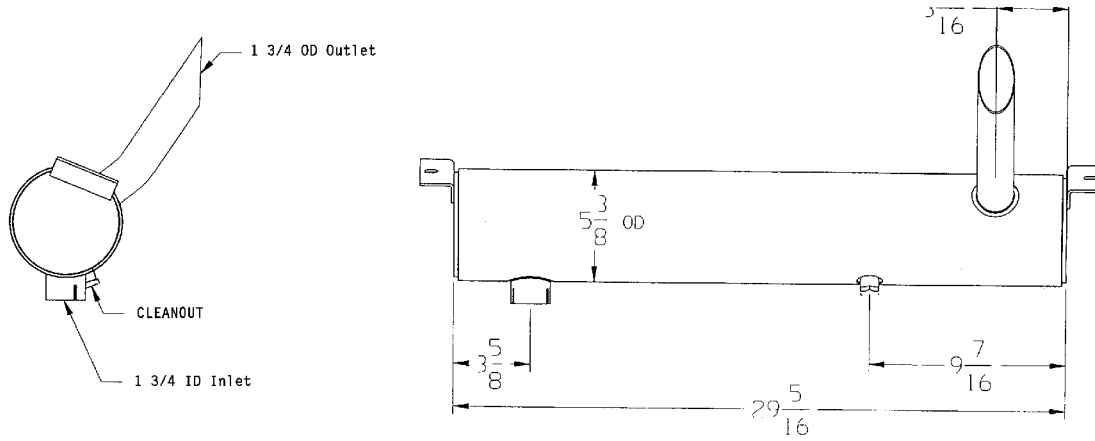

DONALDSON FMM050132

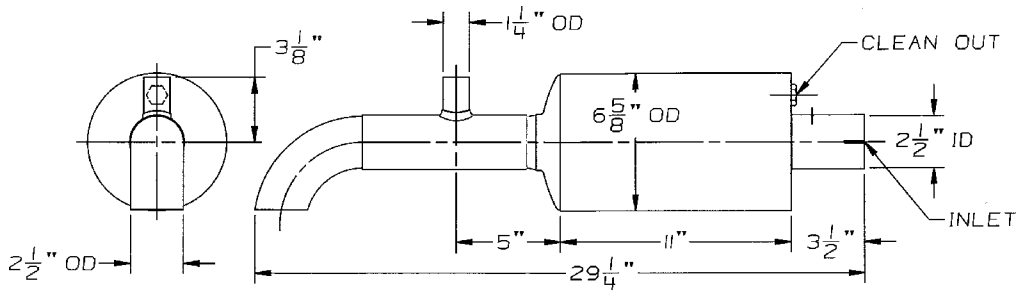

Donaldson FMM065106

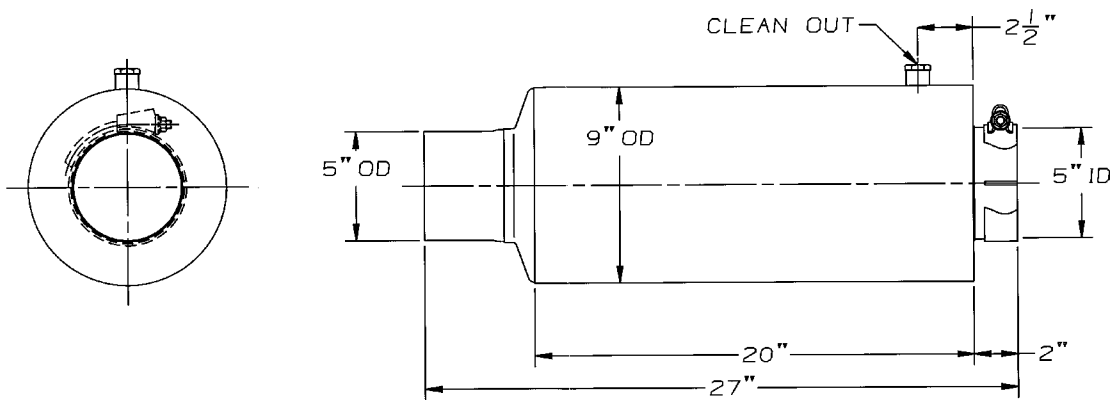

Donaldson FMM090843

ECHO

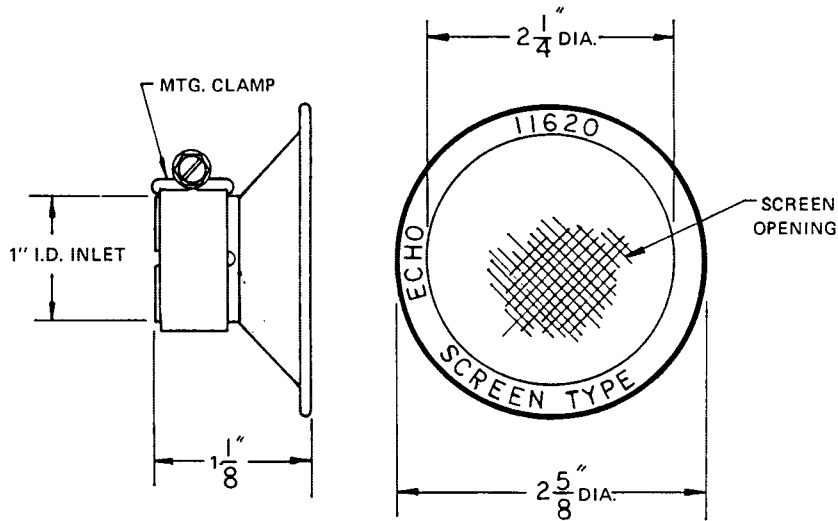

11620

EES

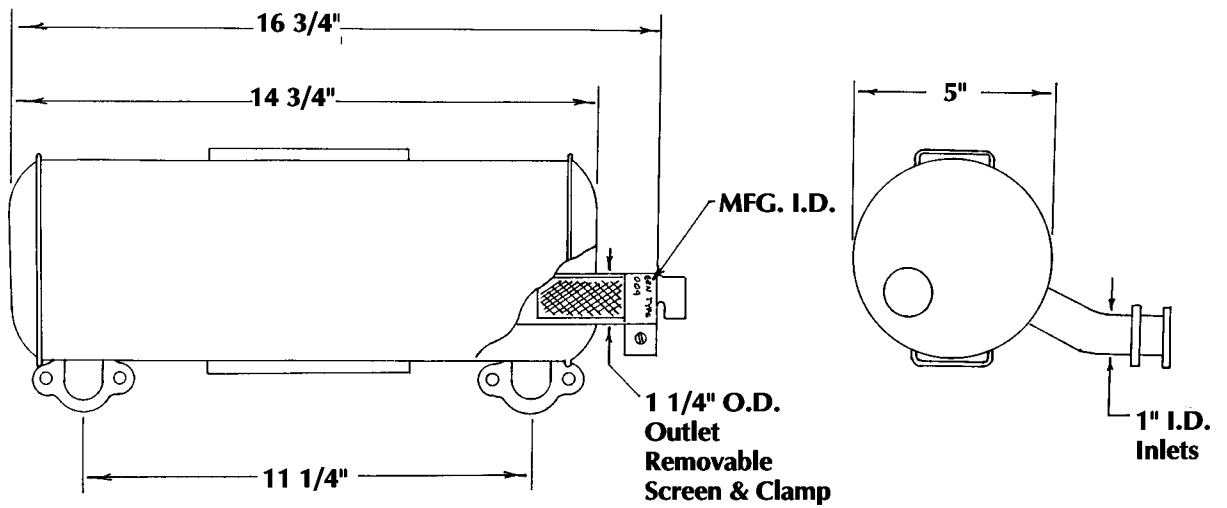

EES 16009

EES

EES (continued)

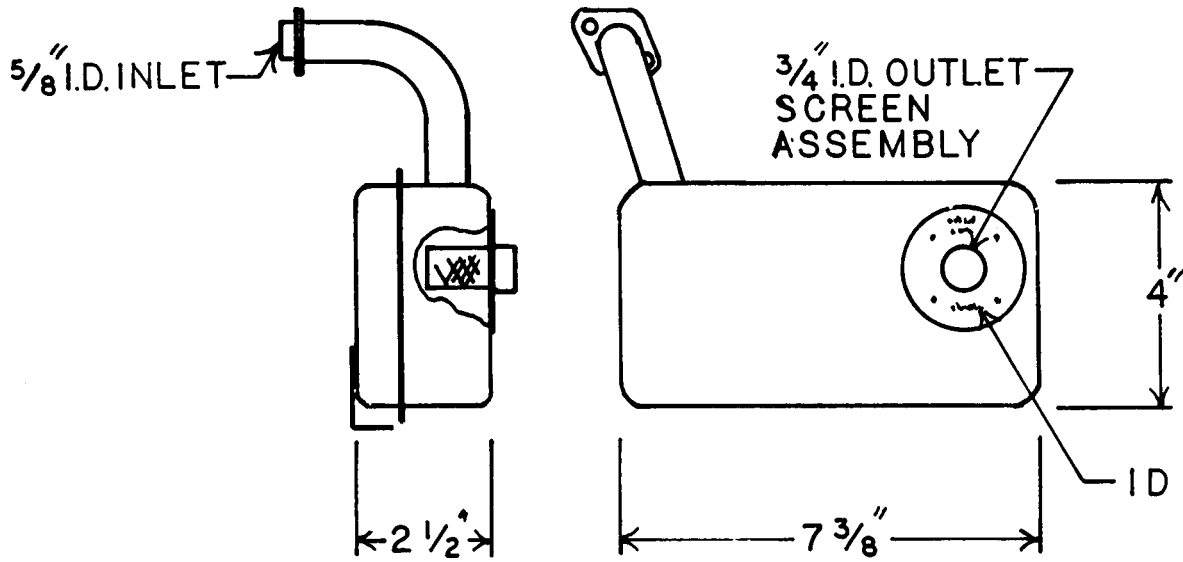

EES 890911-9

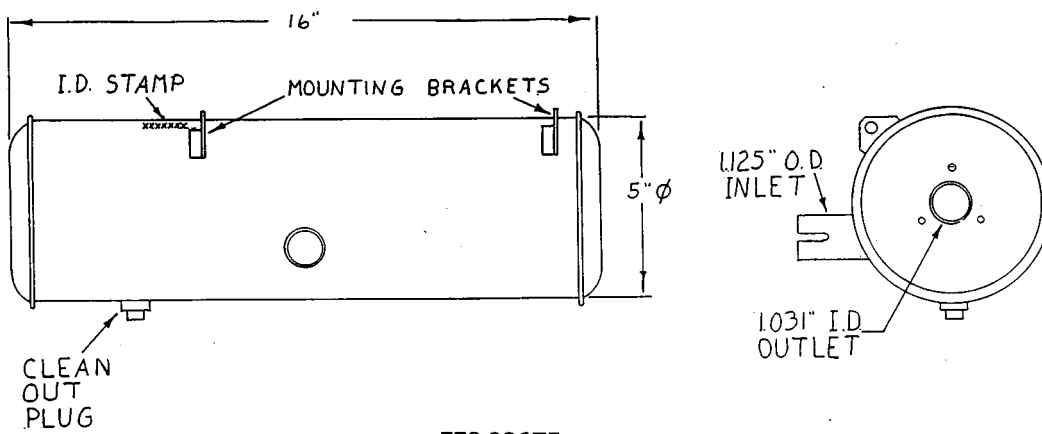

EES 92675

EES (continued)

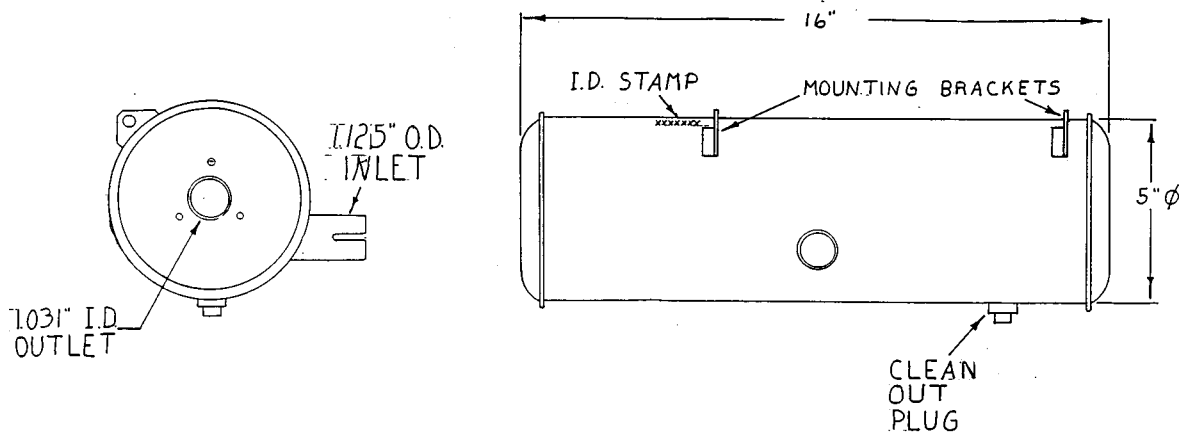

EES 92675A

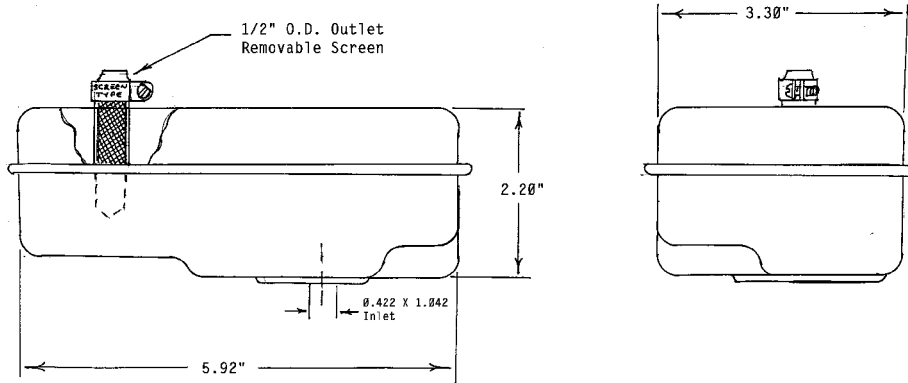

Engineered Exhaust System
EES 0053371

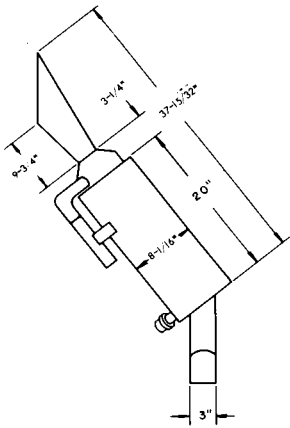

B16647-1

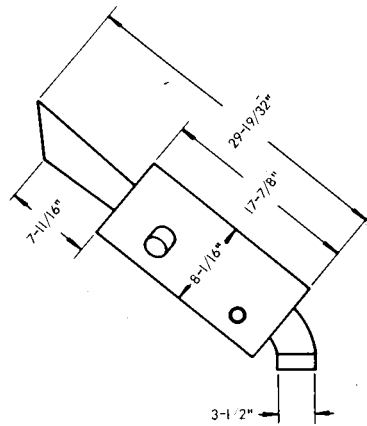

B17345

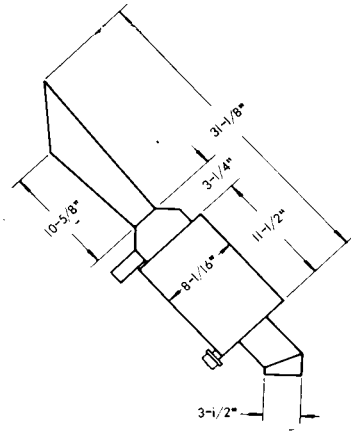

B18854

For C15626 see C16085

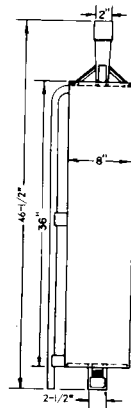

C16085

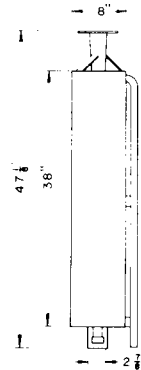

C22001

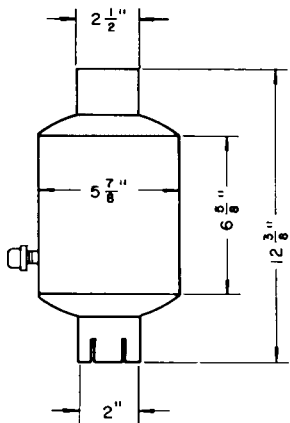

Model 20B

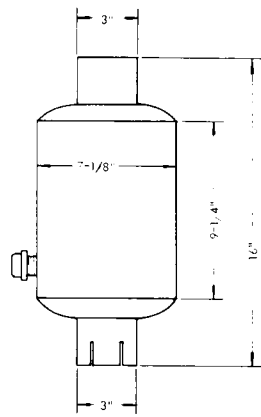

Model 30B

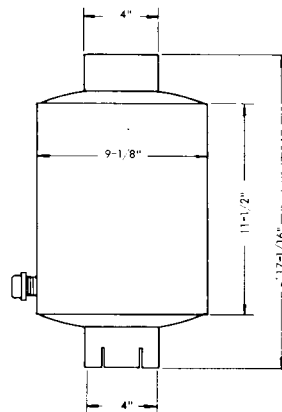

40B

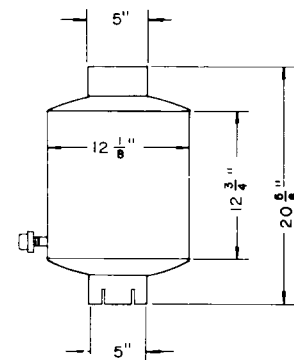

50B

FMF

DIM	RANGE
A	7/8" - 1 1/2"
B	11" - 15"

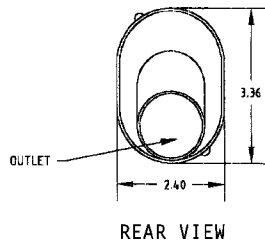
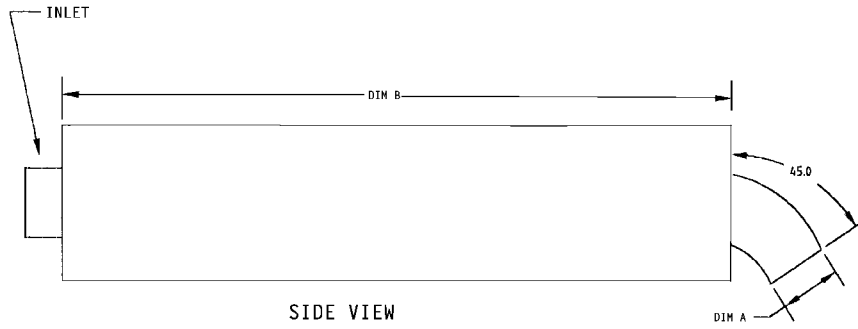

FMF TDS-3

DIM	RANGE
A	7/8" - 1 1/2"
B	11" - 15"

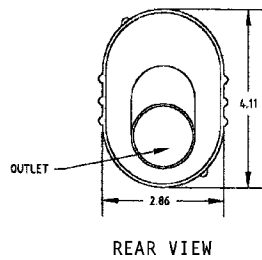
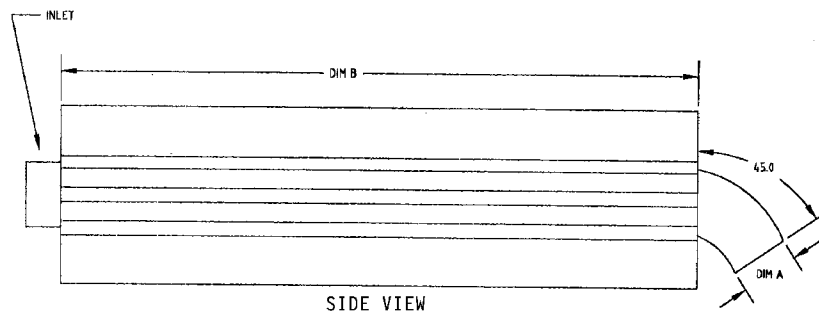

FMF TDS-1

FMF

FMF (continued)

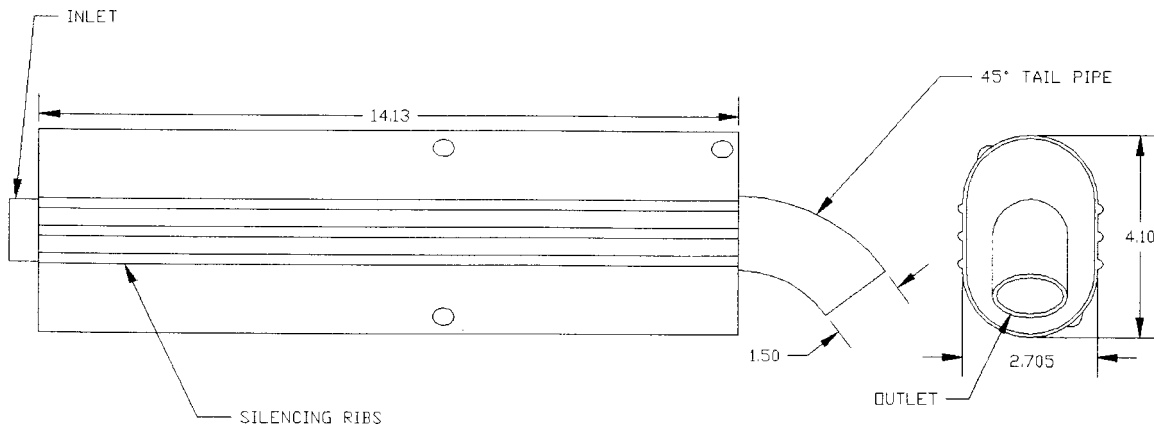

FMF Tru-Tec TDS-1

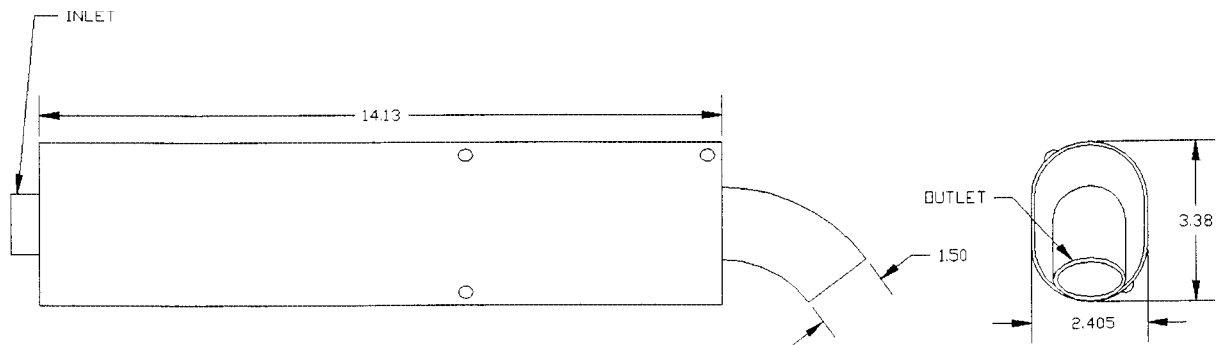

FMF Tru-Tec TDS-2

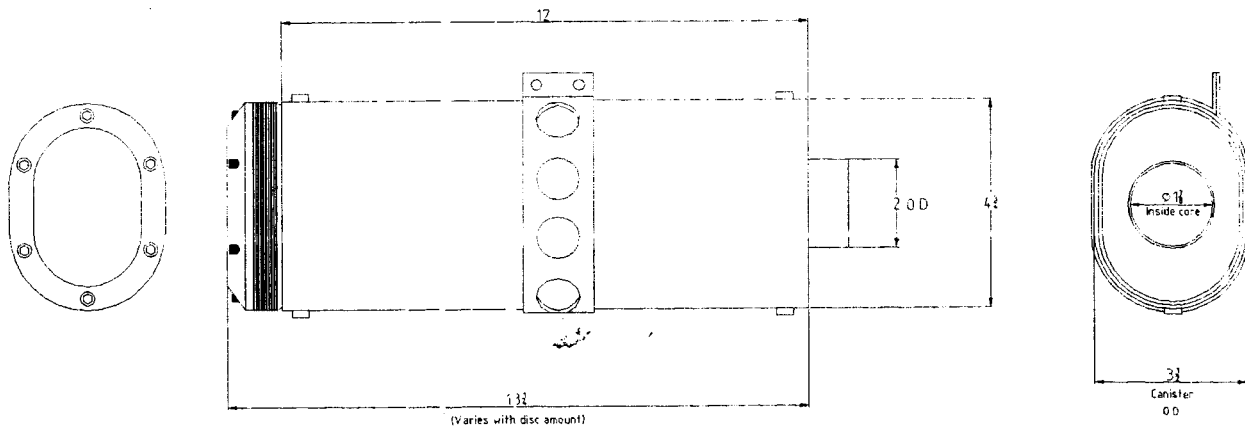

FMF IDSE model 1000

FORESTER

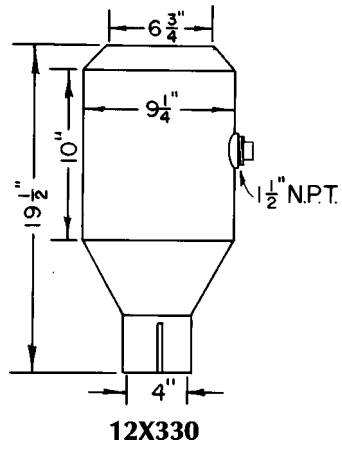

FUJI

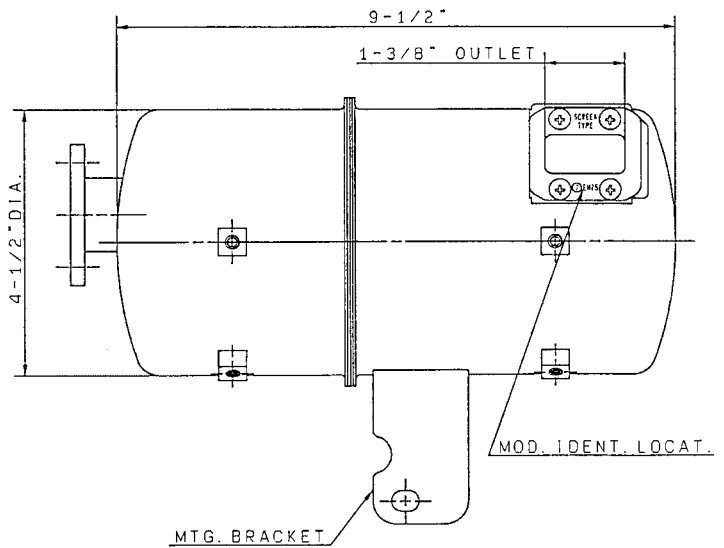
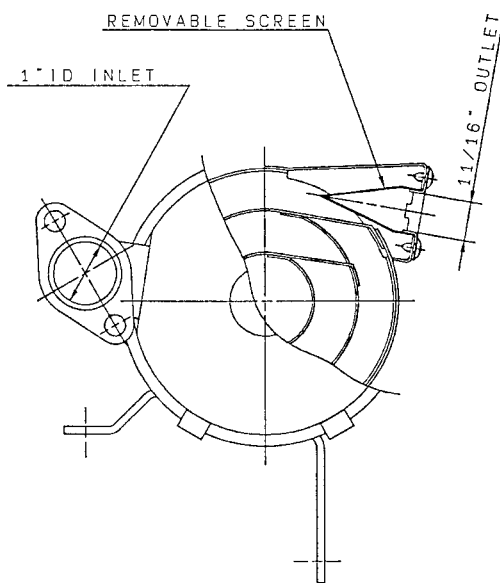
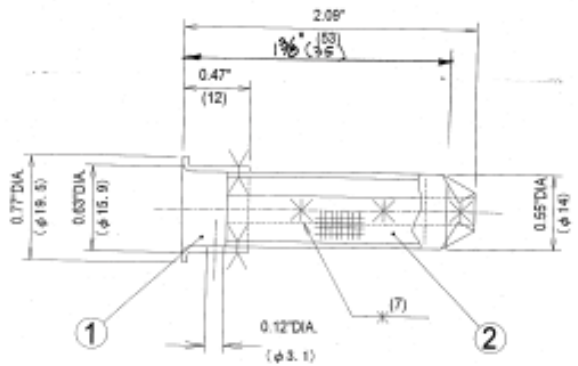
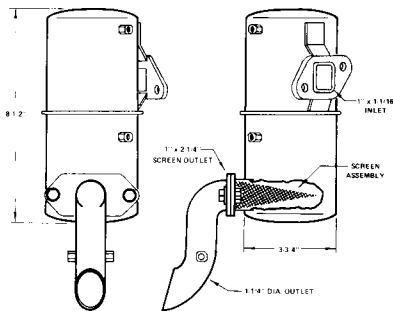

FUJI

FUJI (continued)

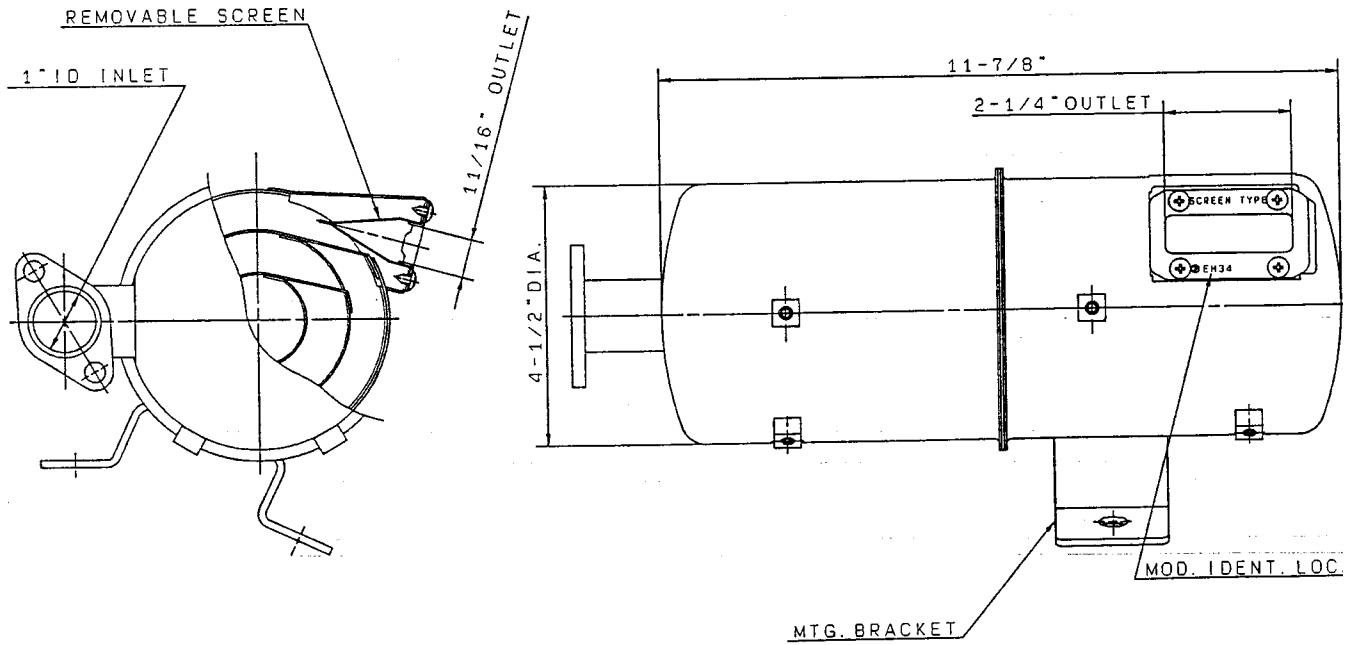

EH34

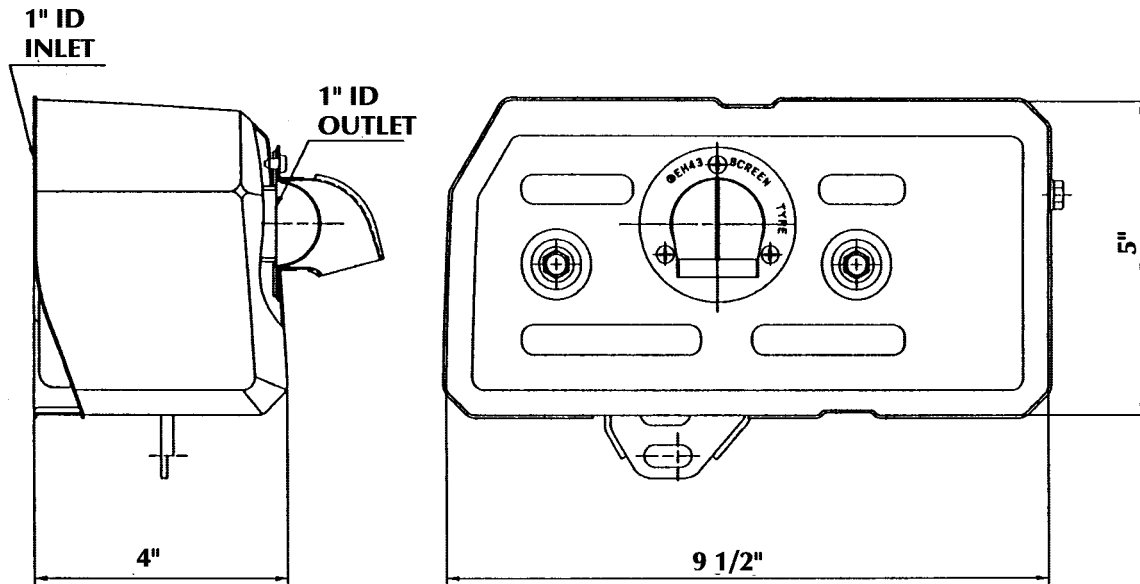

FUJI EH43

FUJI (continued)

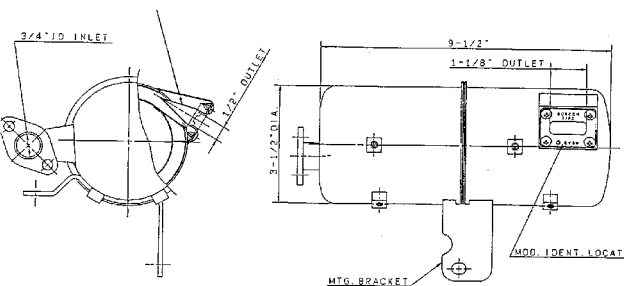

EY20

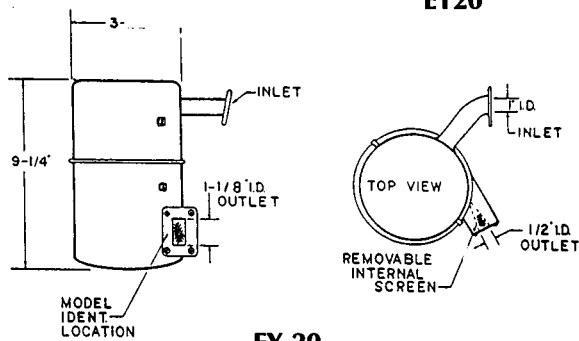

EY-20

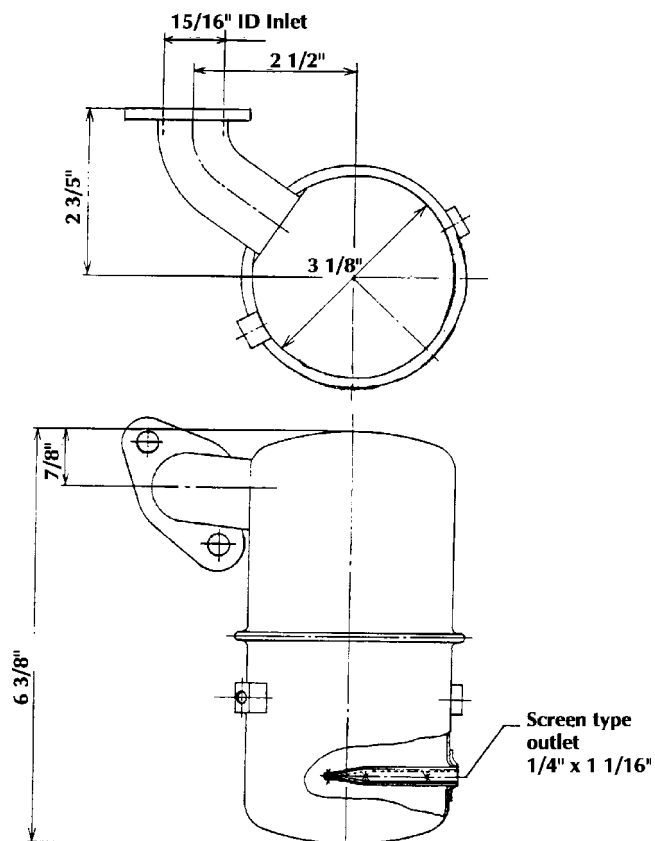

EY20-STD

FUJI

FUJI (continued)

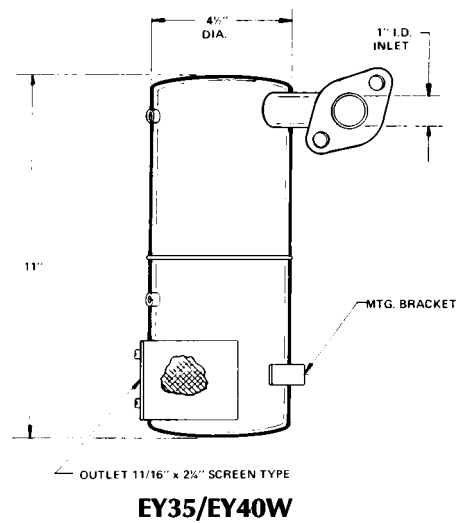
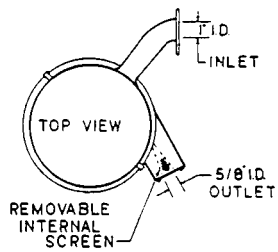
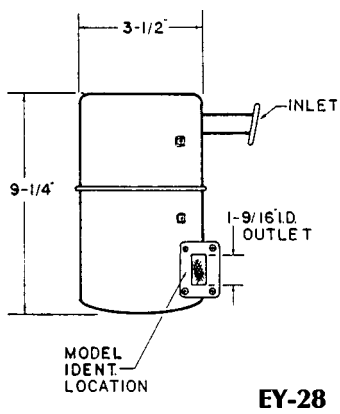
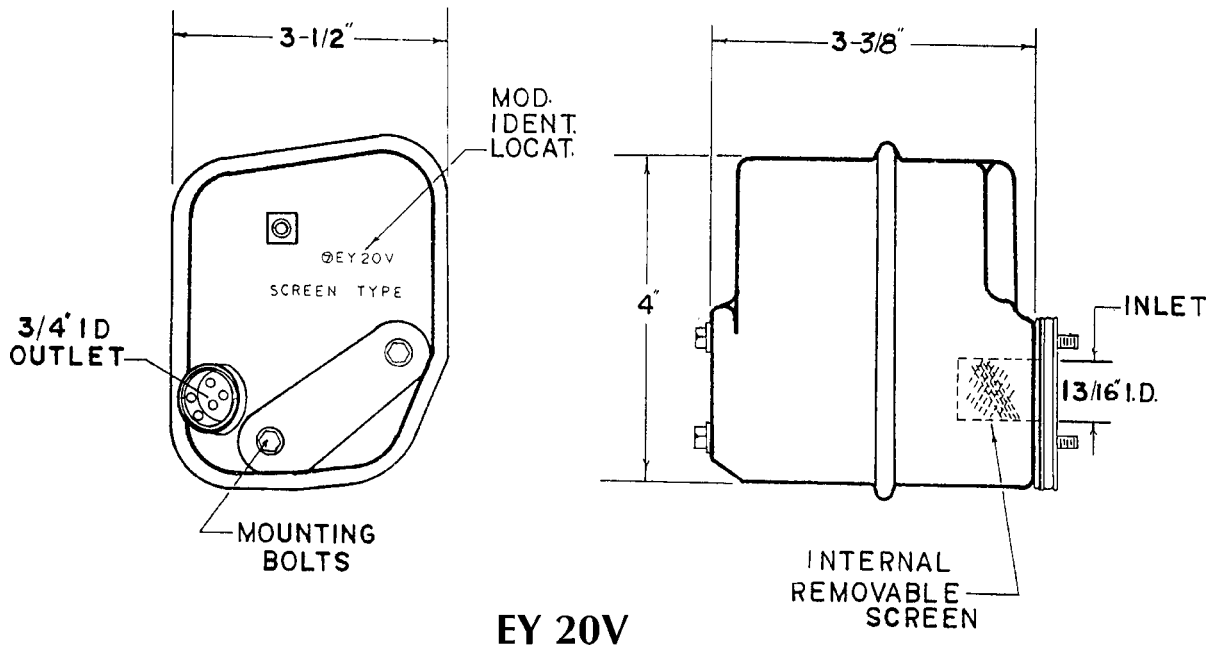

FUJI (continued)

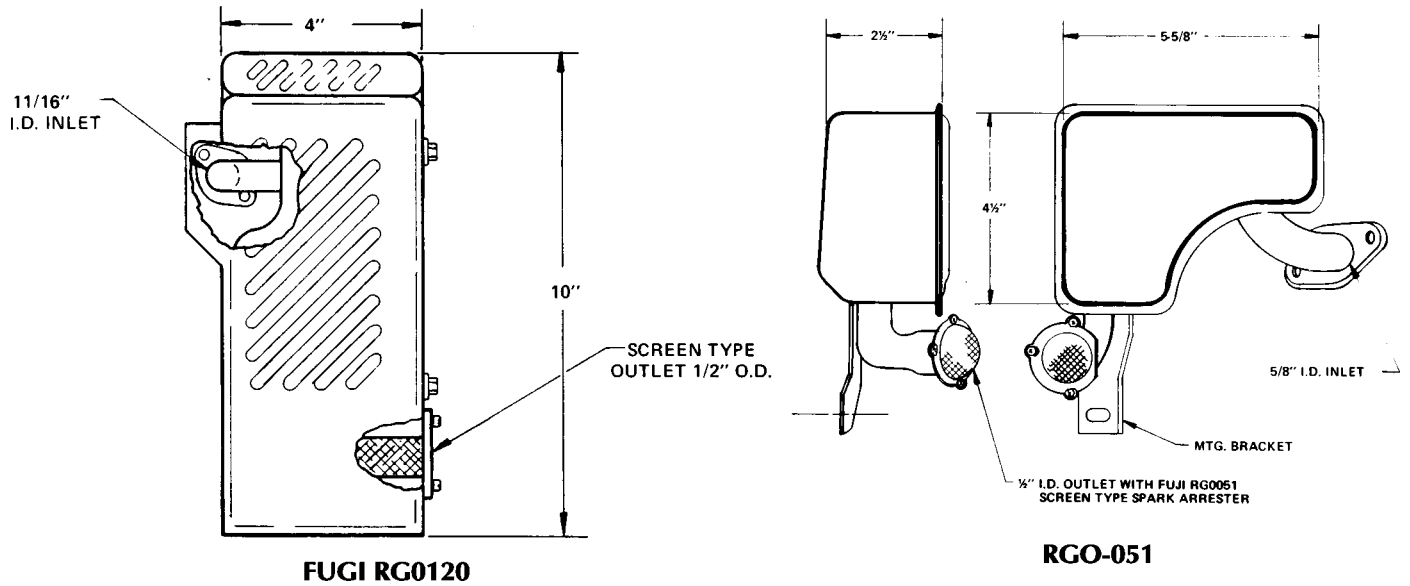

GENERAC



For Generac	30699	—	See Nelson	T-11068C
" "	31145	—	" "	T-11159
" "	33232	—	" "	T-11606
" "	37924	—	" "	T-13304 (Approved as T-9458)
" "	37936	—	" "	T-12760B
" "	38560	—	" "	T-13265
" "	39081	—	" "	T-13572
" "	39247	—	" "	T-9458
" "	43951	—	" "	T-14315
" "	43952	—	" "	T-14316
" "	43953	—	" "	T-14321

GENERAC

GENERAC (continued)



Note: Muffler and screen identical. Different inlet tube length and shape to fit a "Tecumseh" or "Briggs & Stratton" engine.

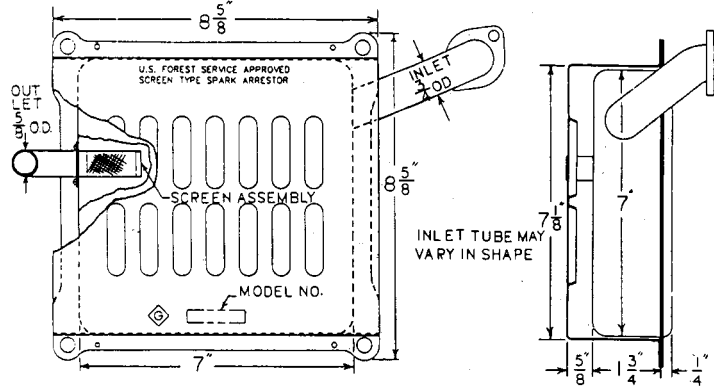

GENERAC 72082 and 72281

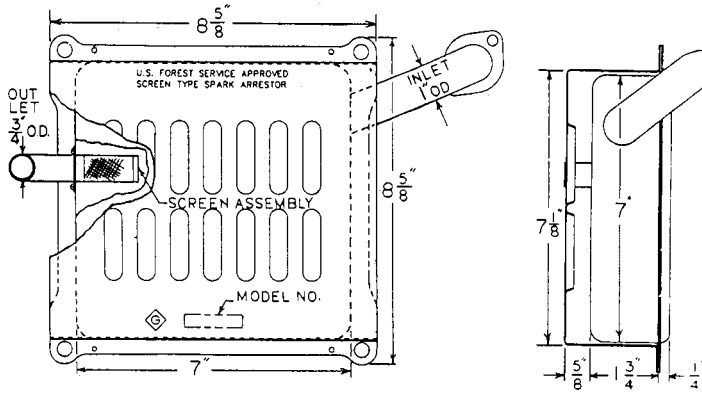

GENERAC 72083

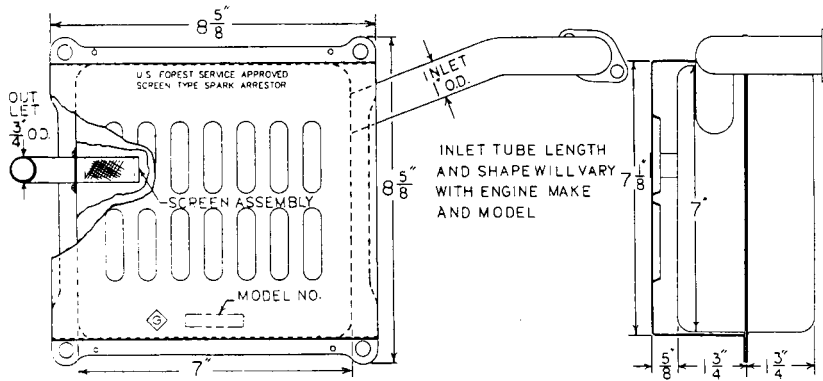

GENERAC 72084 and 72279

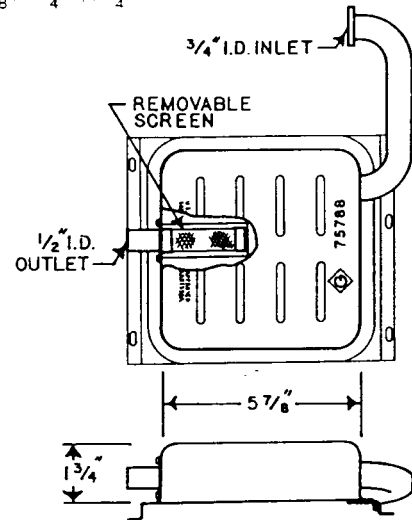

GENERAC 75788

GENERAC (continued)

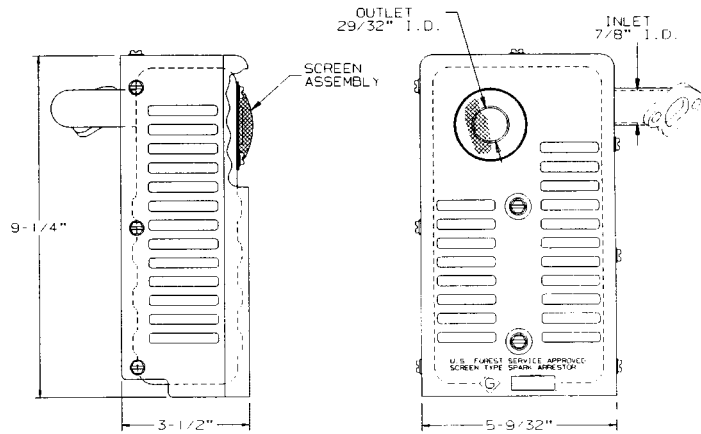

83083

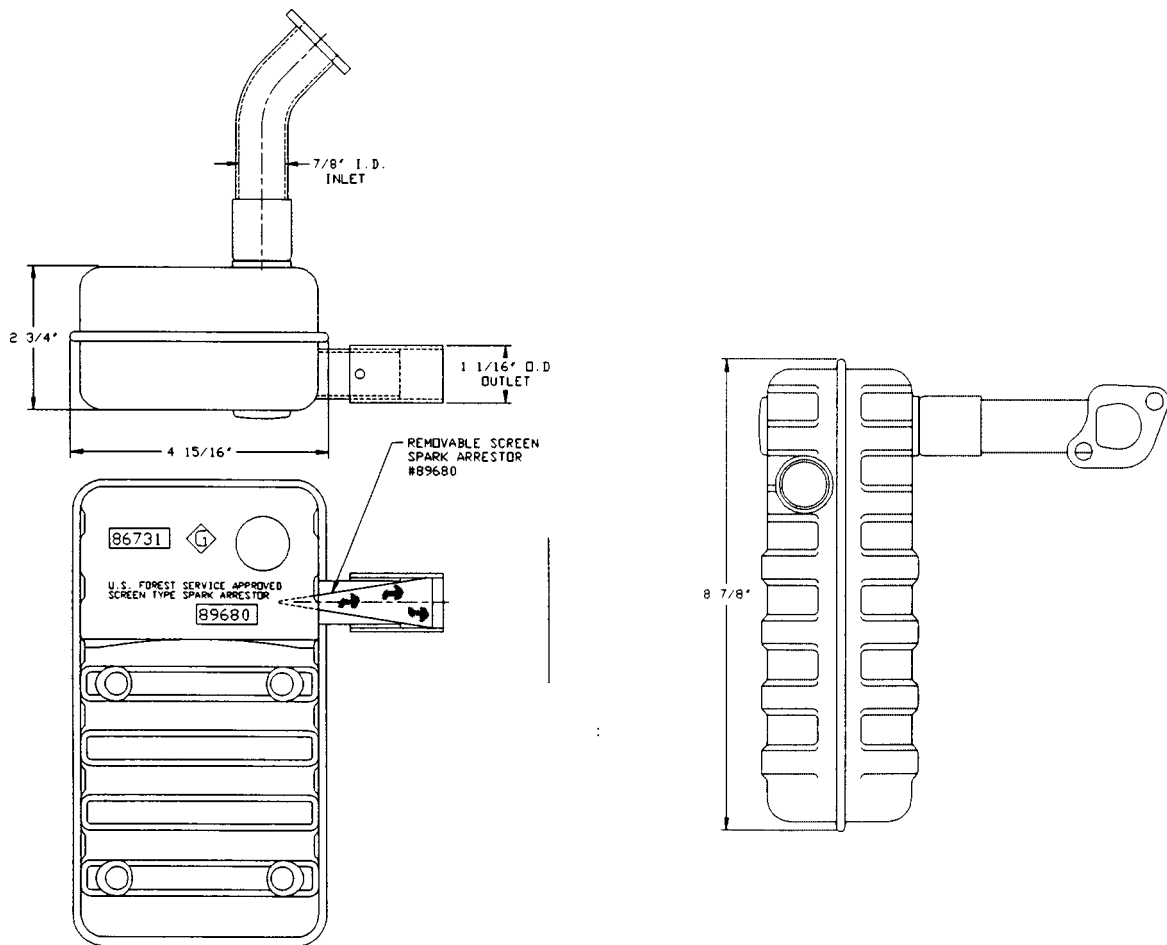

89680

GILL

GILL

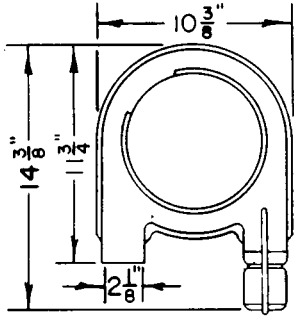

GSF-200

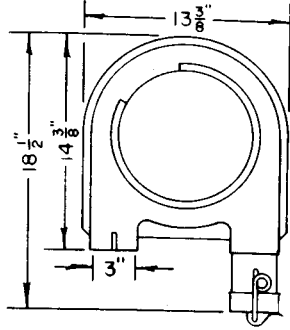

GSF-300

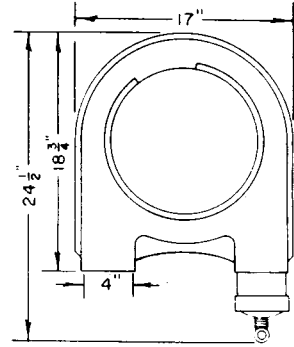

GSF-400

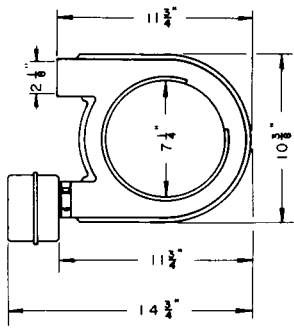

GSH-200

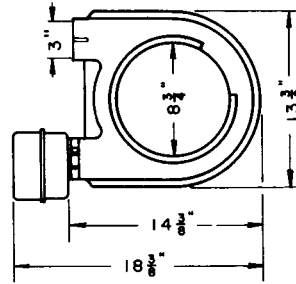

GSH-300

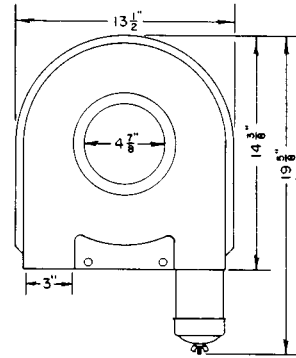

GSO-300

GILL (continued)

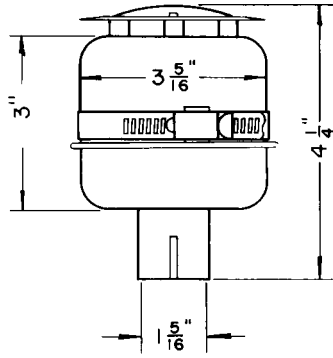

3C

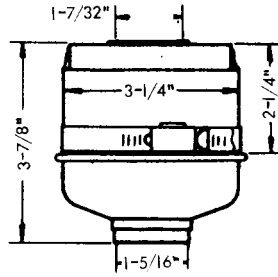

3C-USFS Mod.

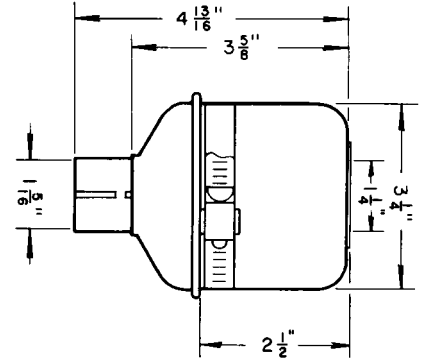

3CIP (Horiz)

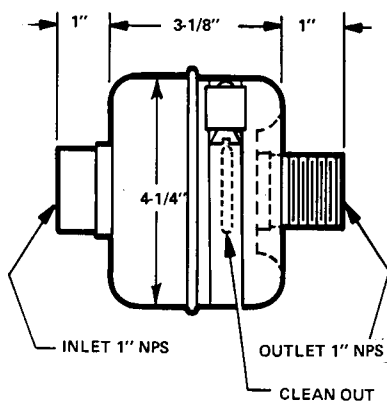

4CIP

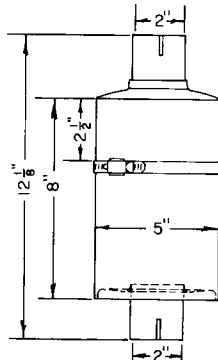

5CV20

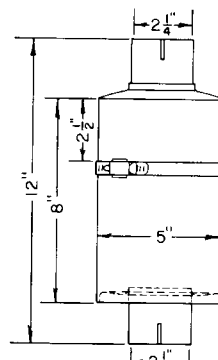

5CV23

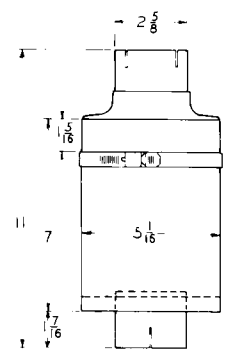

5CV24

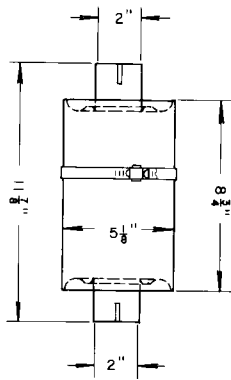

5C20A

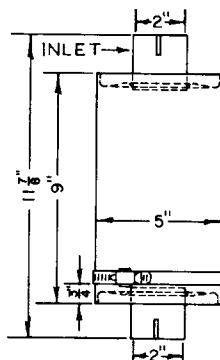

5C20A Inverted

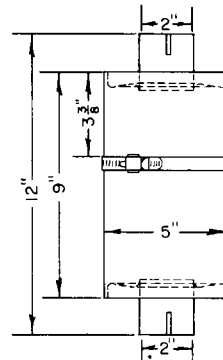

5C20B

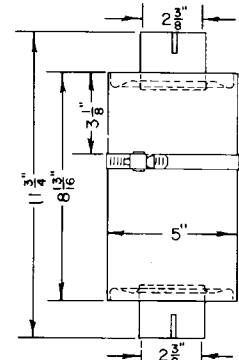

5C23B

GILL

GILL (continued)

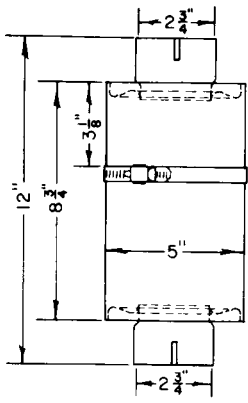

5C26B

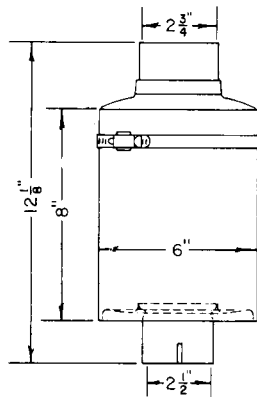

6CV24

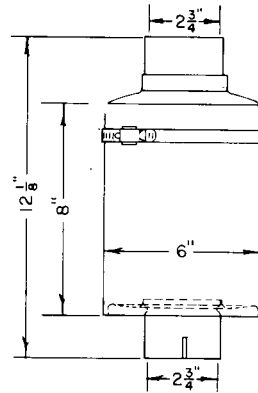

6CV26

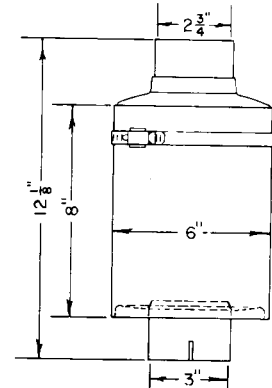

6CV30

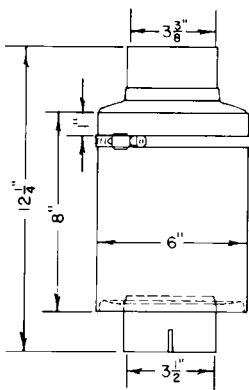

6CV34

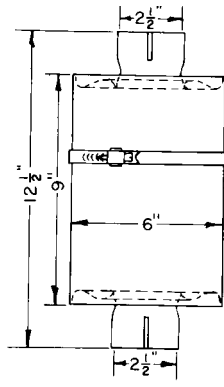

6C24 (9in.)

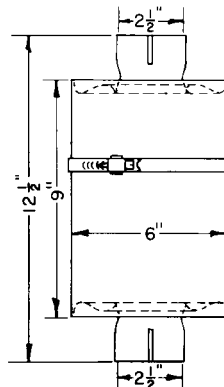

6C24 (12in.)

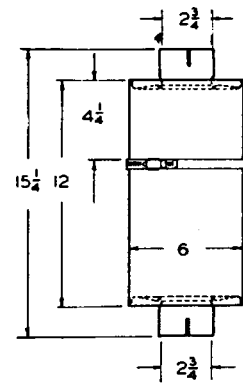

6C26 (12in.)

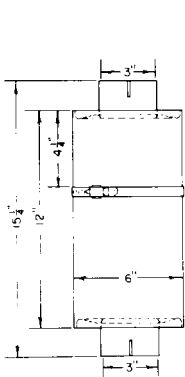

6C30 (12 in.)

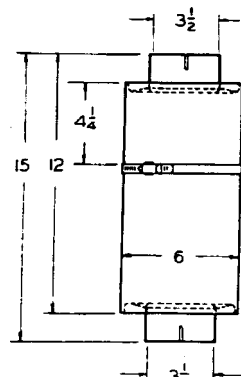

- 6C34 (12in.)

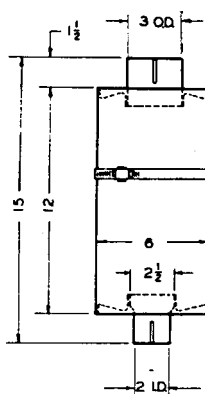

6C2030 (12in.)

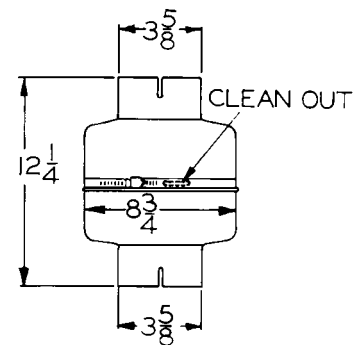

8CV34

GILL (continued)

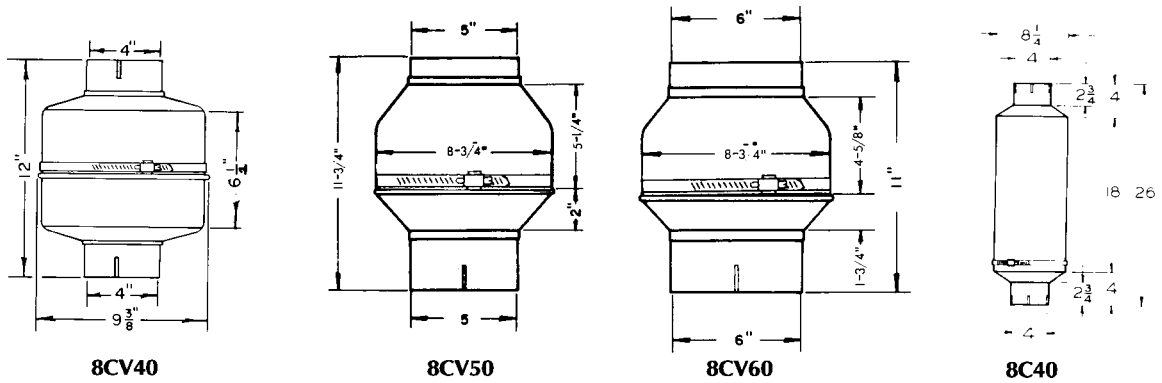

GILSON

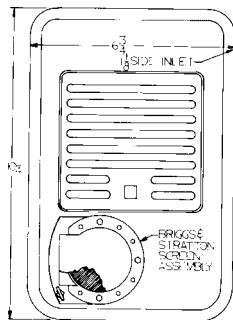

36742 Screen Assembly 392154

GORMAN-RUPP

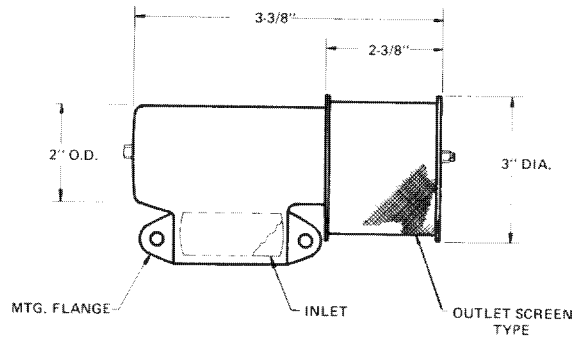
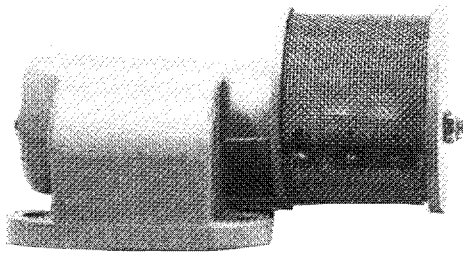

462611-018

HALE

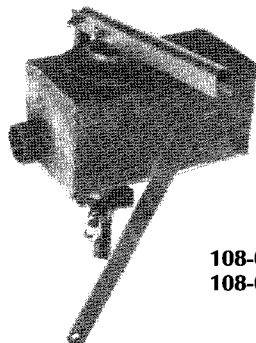

108-0230-02
108-0230-06*

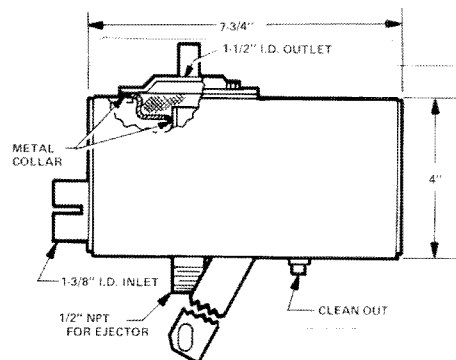

*Modified 108-0230-02 for use on 1-cylinder of an engine. An elbow has been added to the inlet to accommodate mounting.

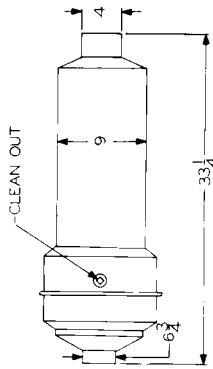

S.A.M. 712

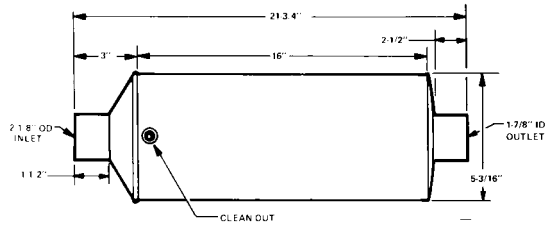

SASR 36-H, 3AAXH

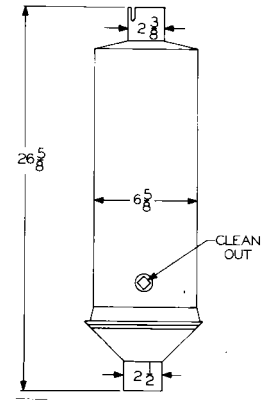

SASR 48

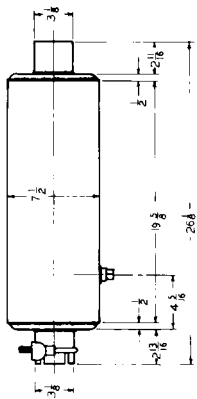

SASR 48-H

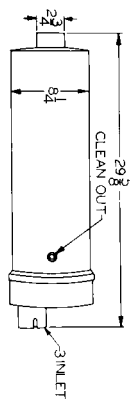

SASR 59

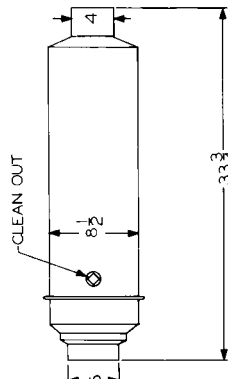

SASR 69-H

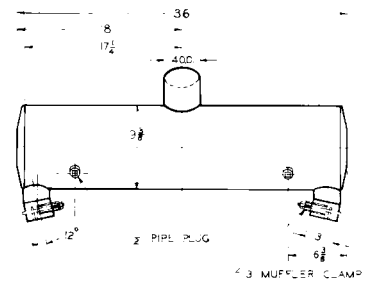

SASR 559

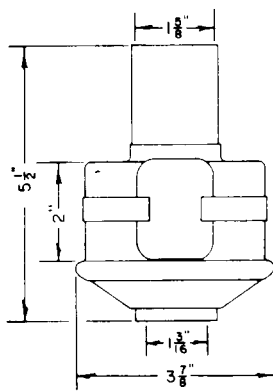

1AA

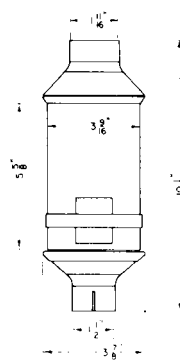

1AA S.A.M. 13-18

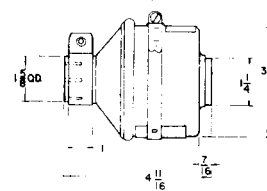

1AAXH

HAPCO (continued)

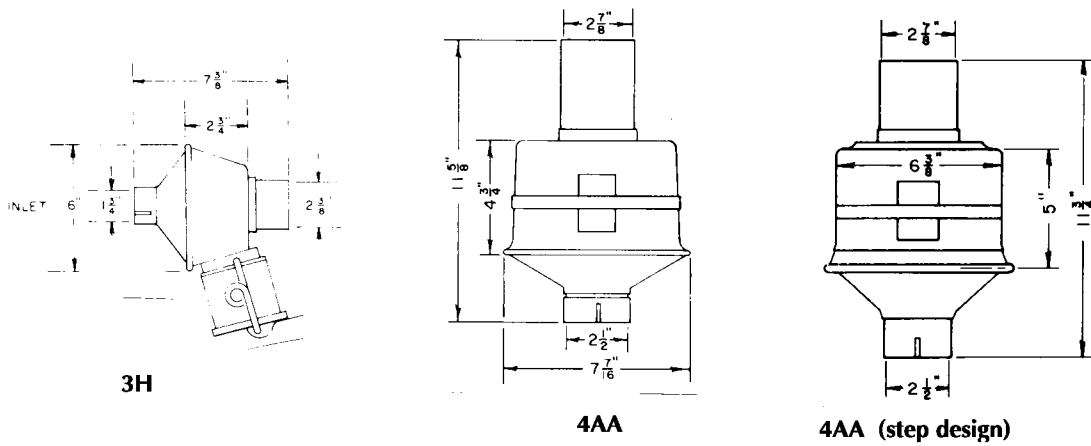
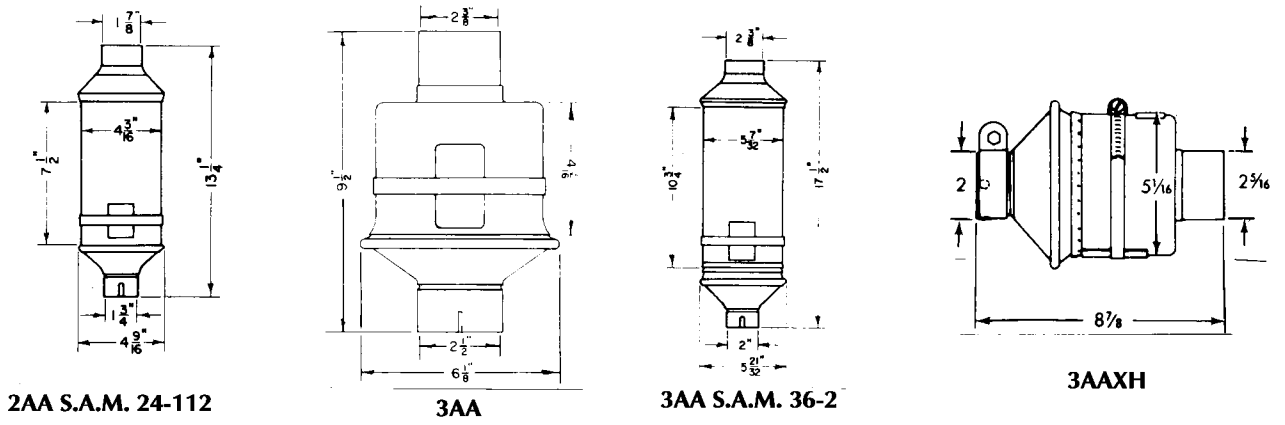
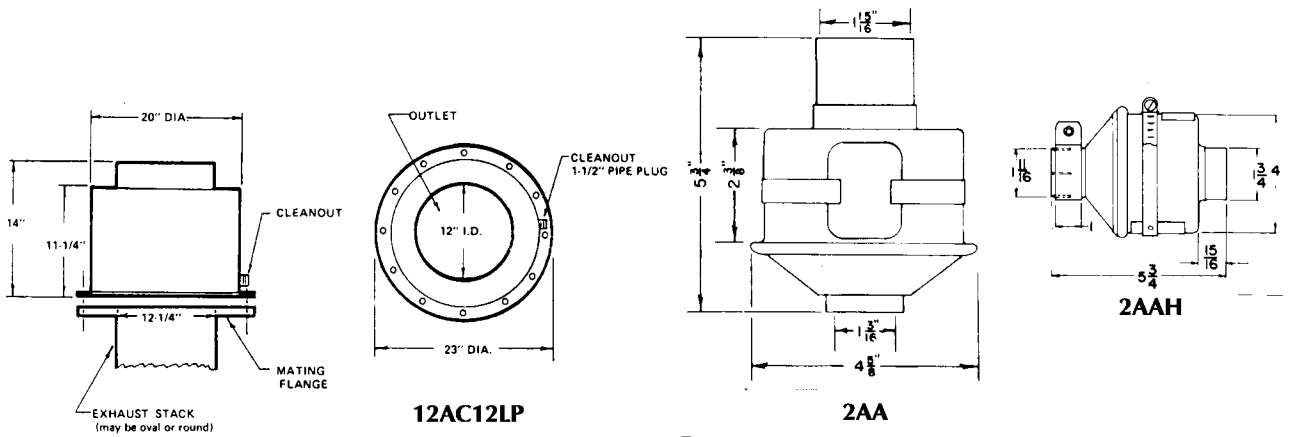

HAPCO

HAPCO (continued)

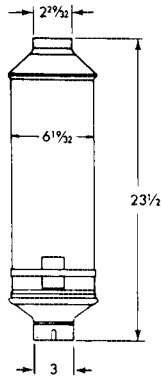

4AA S.A.M. 48-3

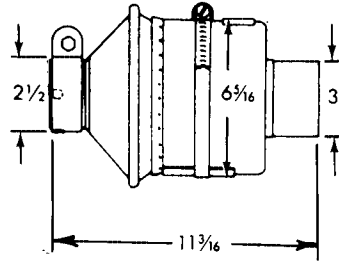

4AAH

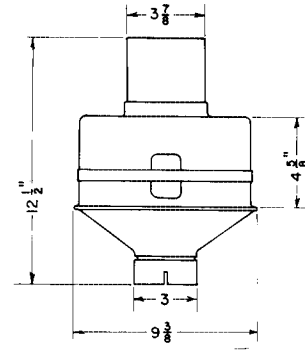

5AA

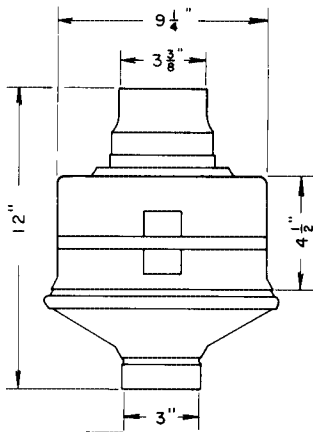

5AA (step design)

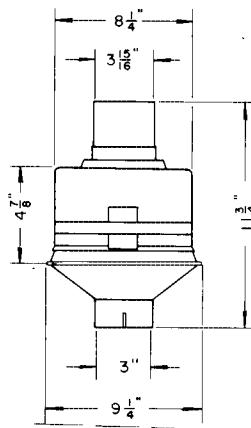

5AA (altered)

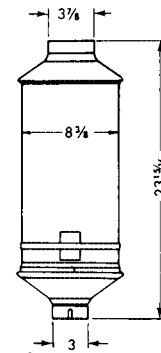

5AA S.A.M. 59-3

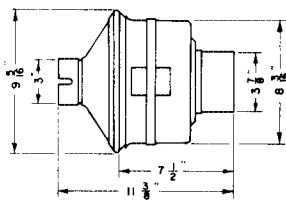

5AAH

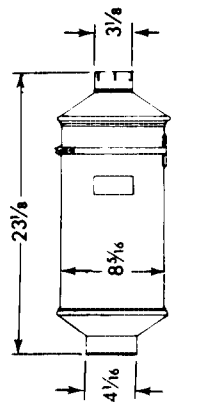

5AAH S.A.M. 59-3

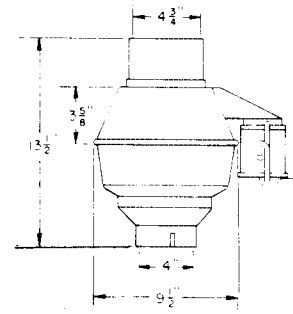

6A OR 6H

HAPCO (continued)

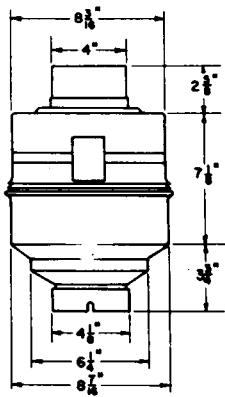

6AA (4" outlet)

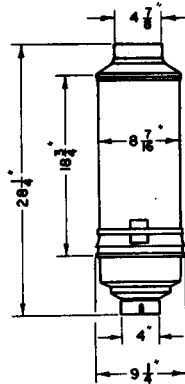

6AA S.A.M. 69-4

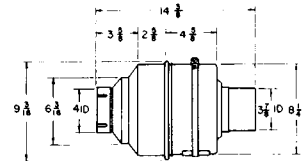

6AAH

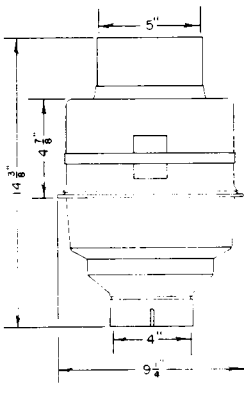

6AB

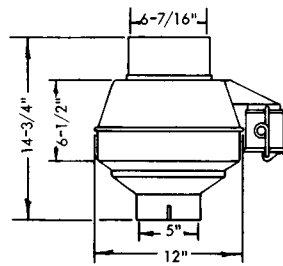

7A OR 7H

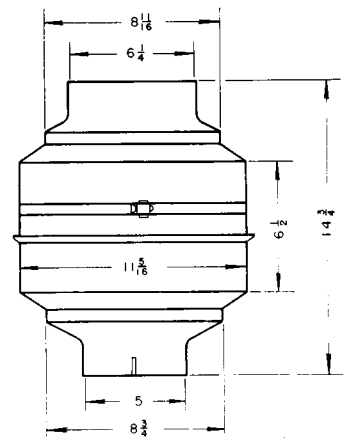

7AB

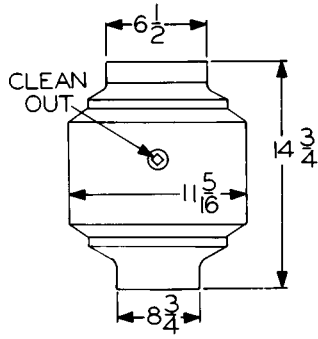

7AC

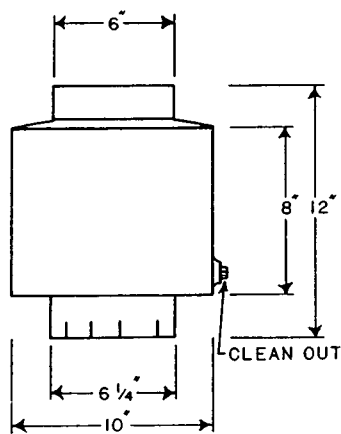

7AC1

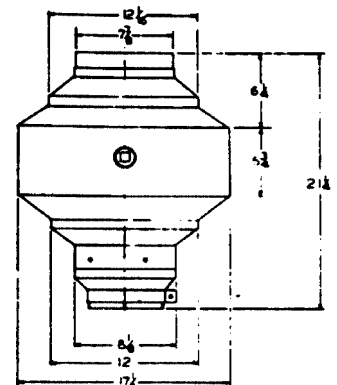

8AB

HARLEY-DAVIDSON

HARLEY DAVIDSON

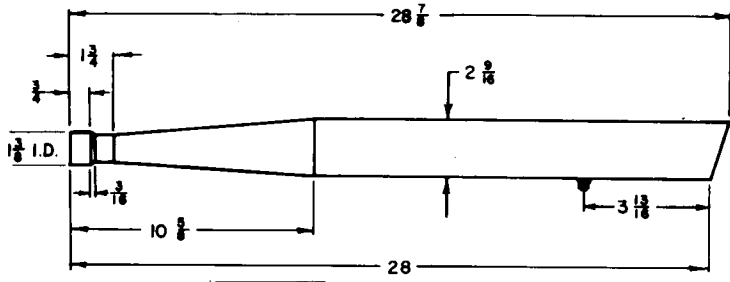

H.D. -1

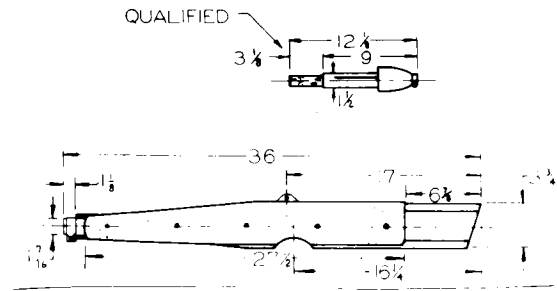

QUALIFIED

H.D. -2

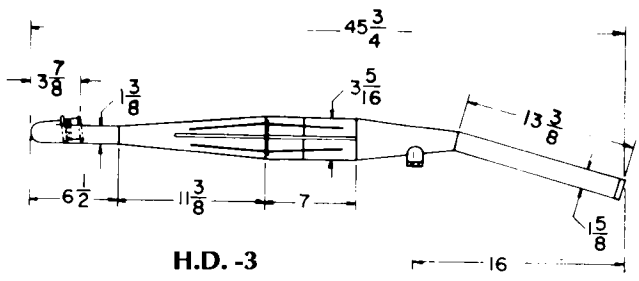

H.D. -3

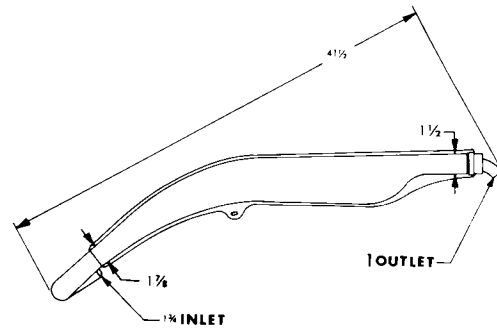

65234-75P

HARLEY-DAVIDSON HARLEY-DAVIDSON-KRIZMAN/HODAKA

HARLEY-DAVIDSON (continued)

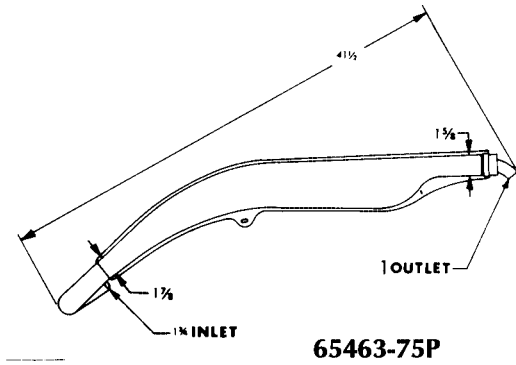
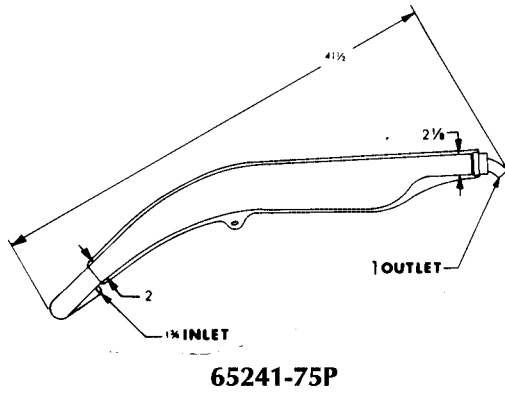

HARLEY-DAVIDSON-KRIZMAN

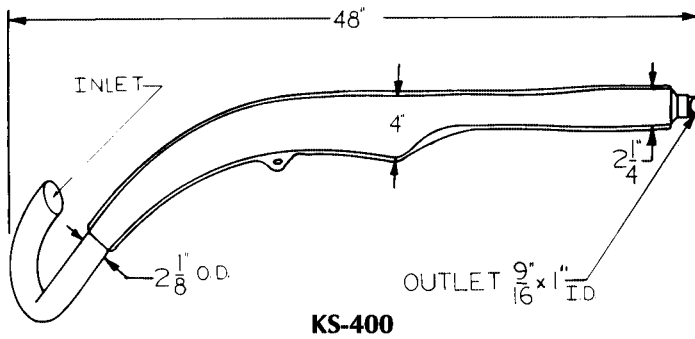

HODAKA

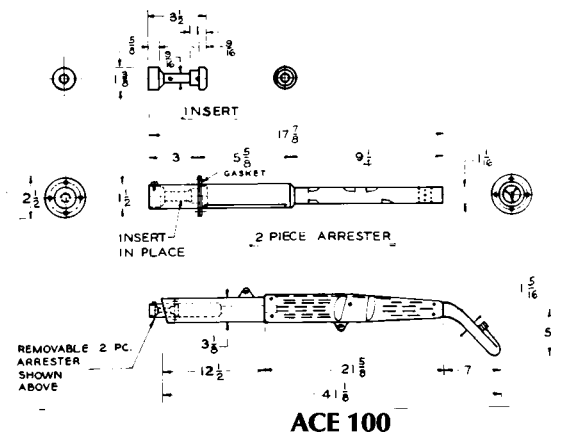
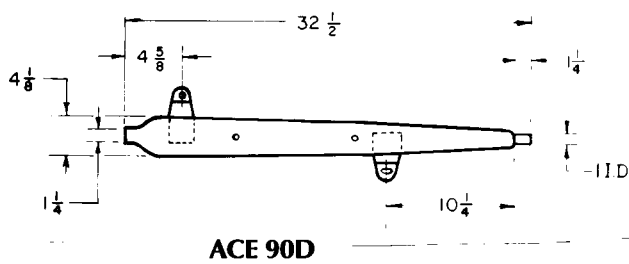

HONDA

HONDA

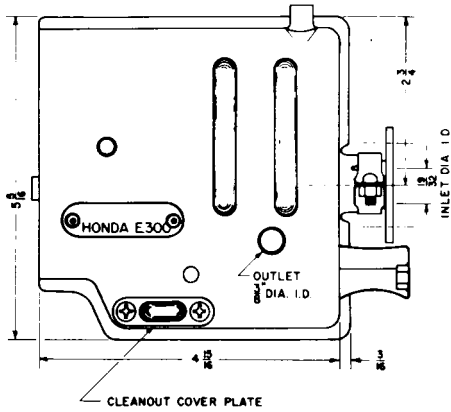

E300

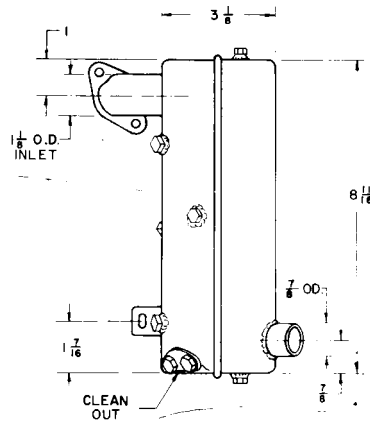

E400

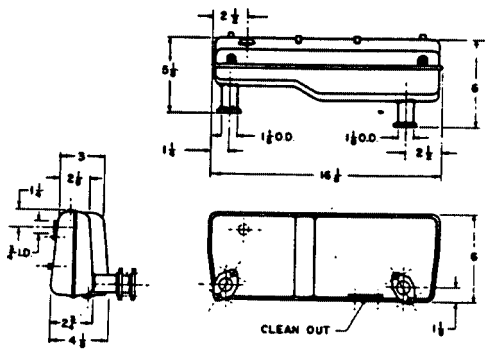

E600

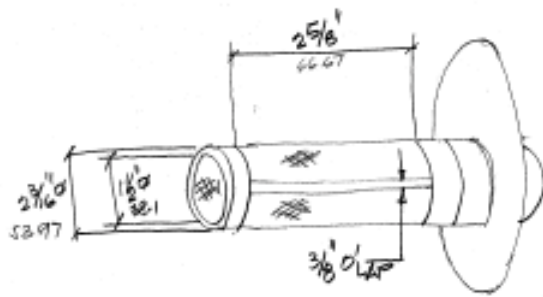

HM HNI A1

HONDA SCREEN TYPE
SPARK ARRESTER HM KCE A1

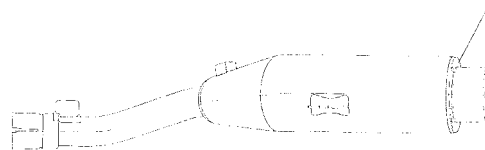

HM KCE A1

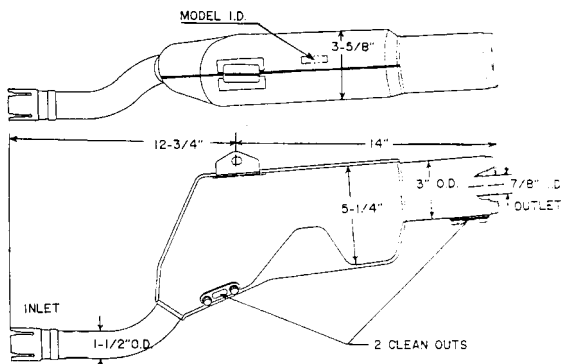

HM KV6A1

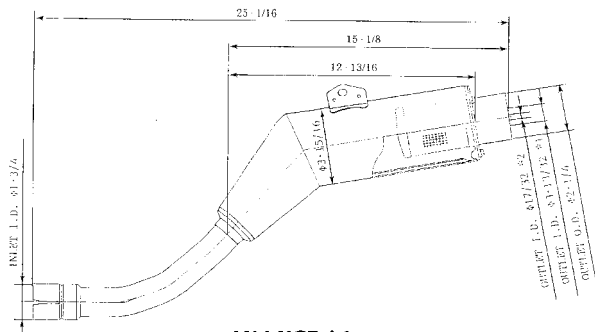

HONDA (continued)

HONDA SCREEN TYPE
SPARK ARRESTER HM KYC A1

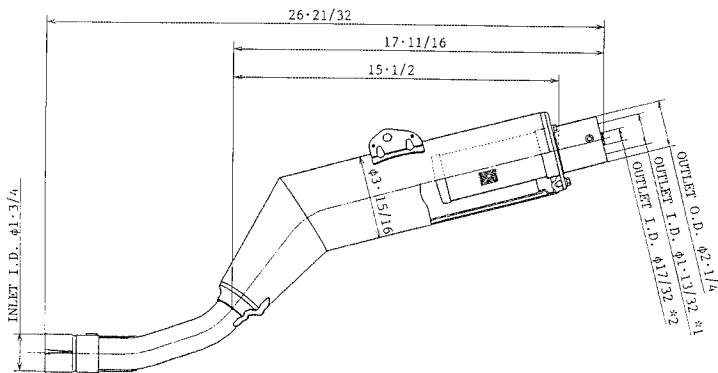
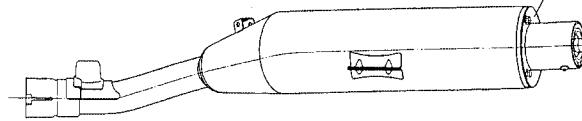

HM KYC A1

29 3/4"

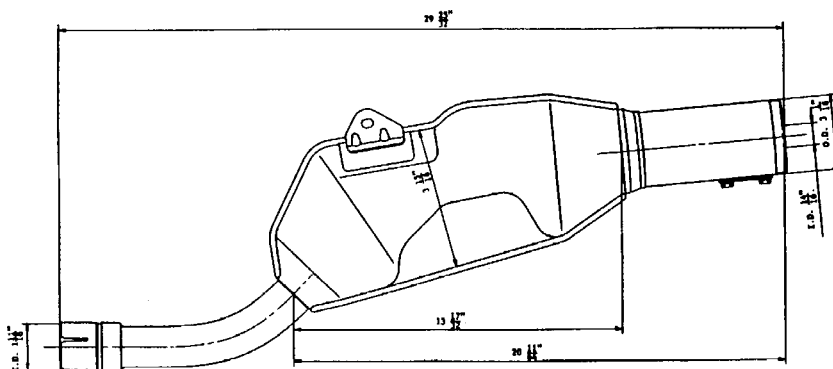
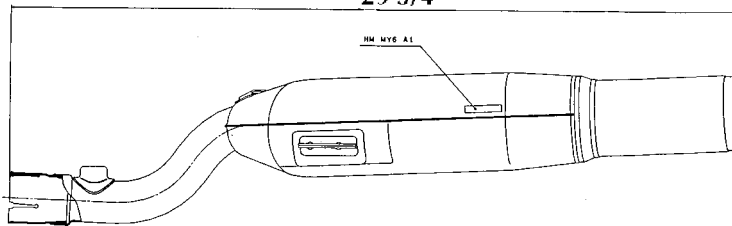

HM-MY6-A1

HONDA

HONDA (continued)

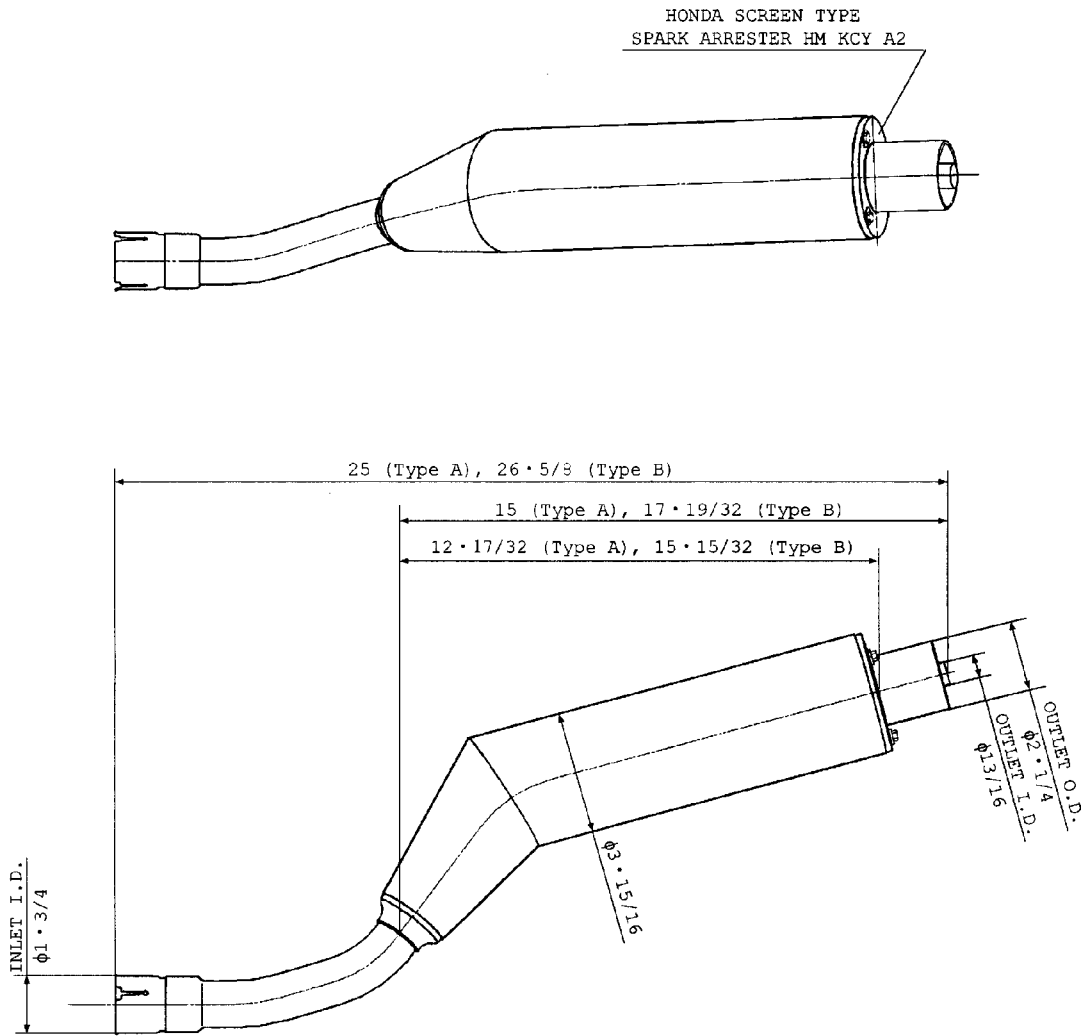

Honda HM KYC A2

Type A : For XR250R
Type B : For XR400R

UNIT:Millimeter (Inch)

HONDA (continued)

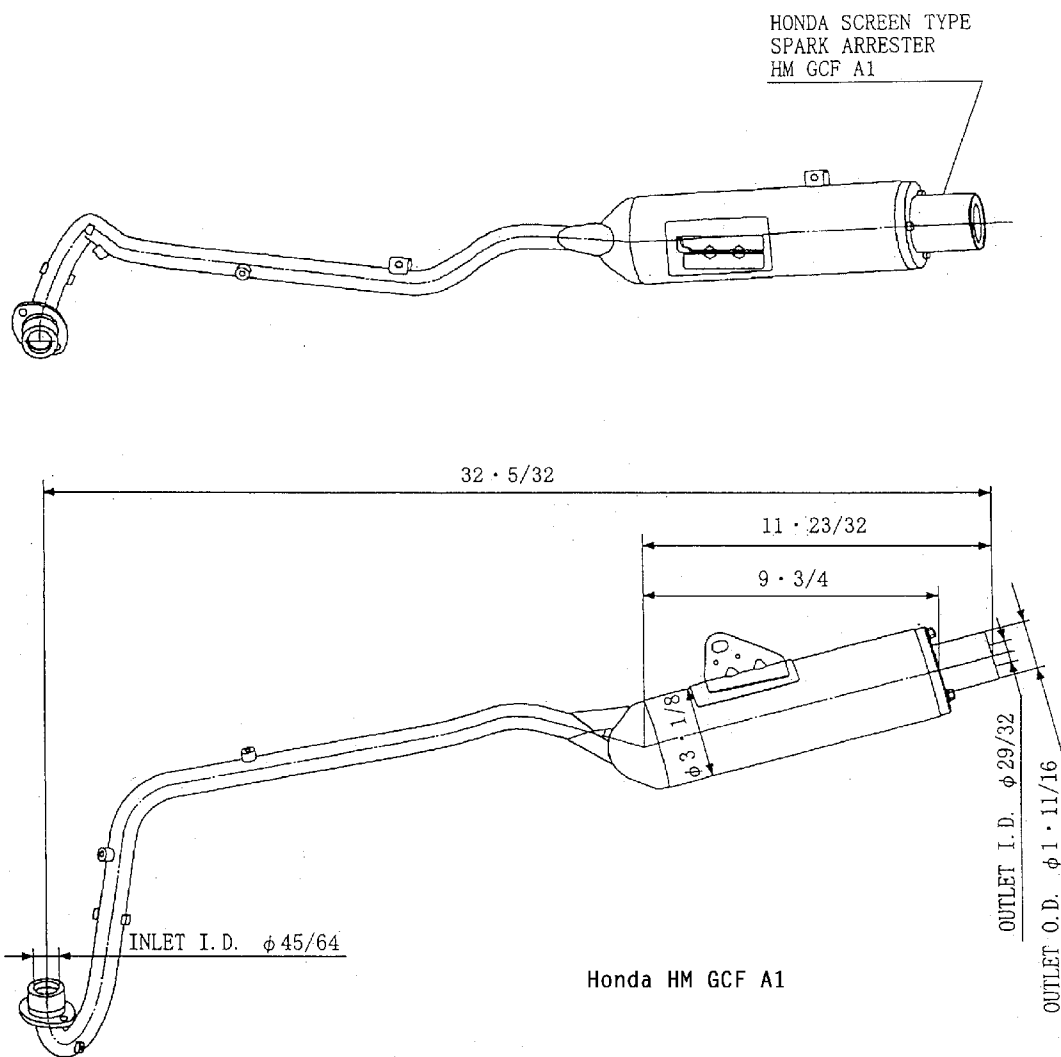

Unit: Inch

HONDA

HONDA (continued)

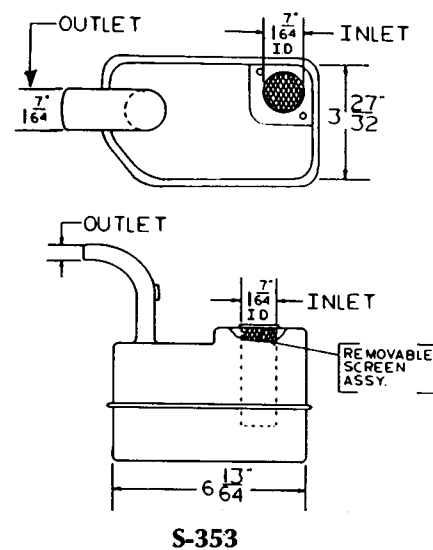
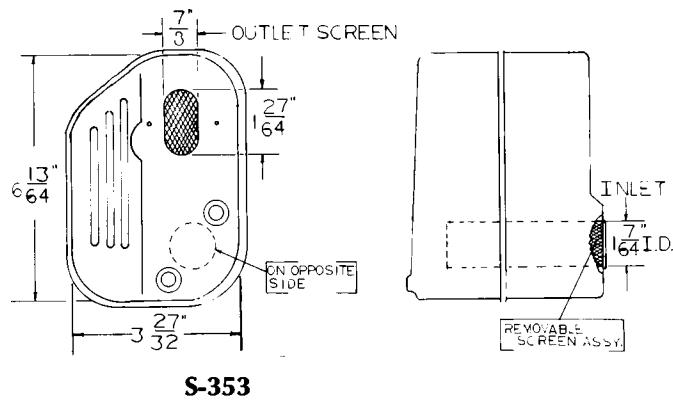
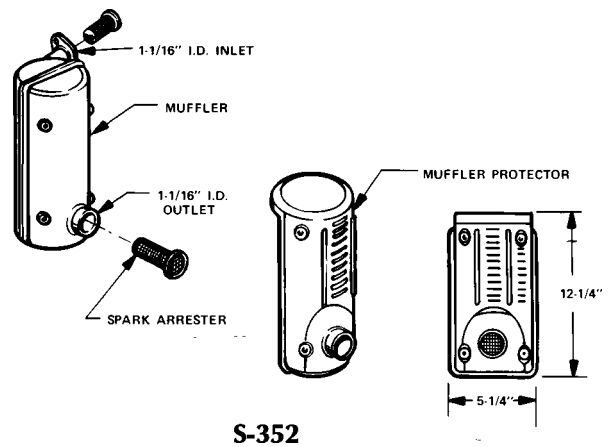
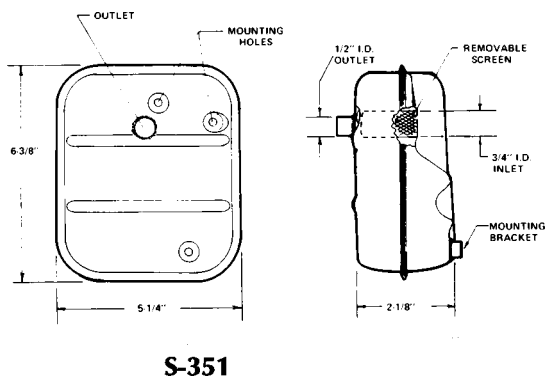
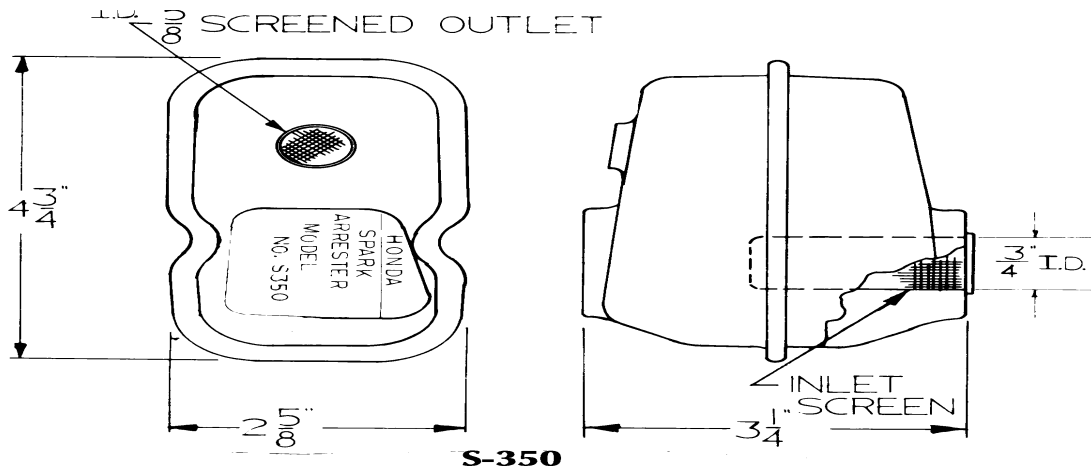

Note: This Honda S-353 has one body shape with outlet opposite inlet, with NO outlet extension, and one body with outlet on same side as inlet—outlet has extension pipe and same screen.

HONDA (continued)

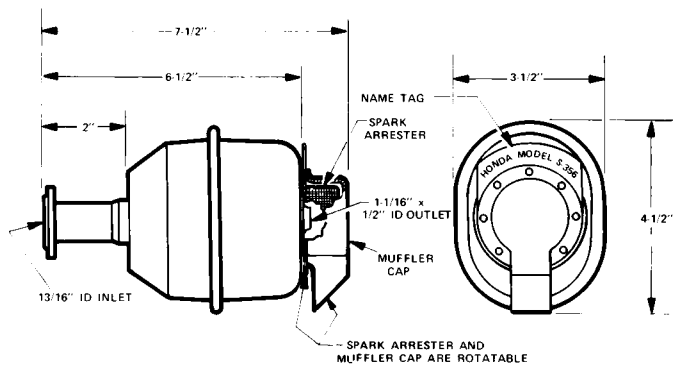
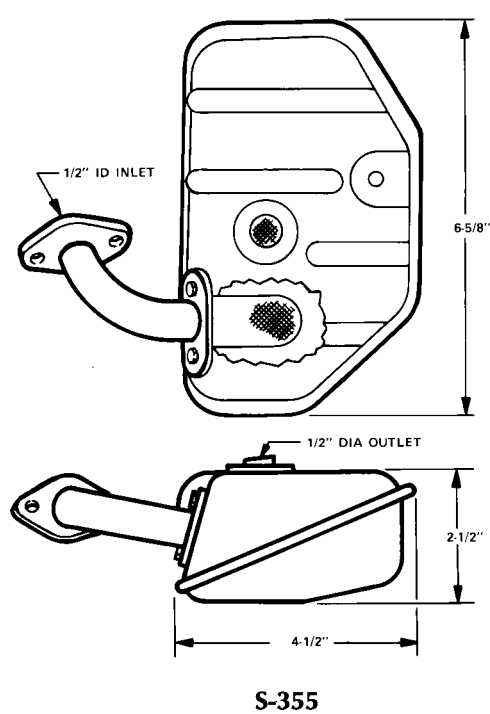
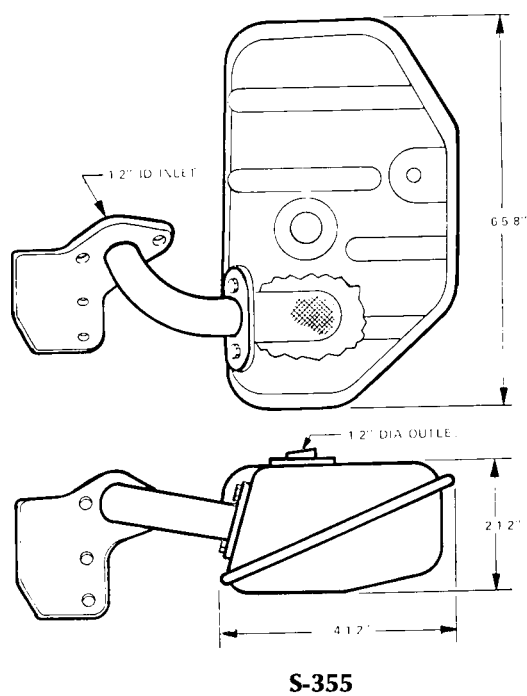
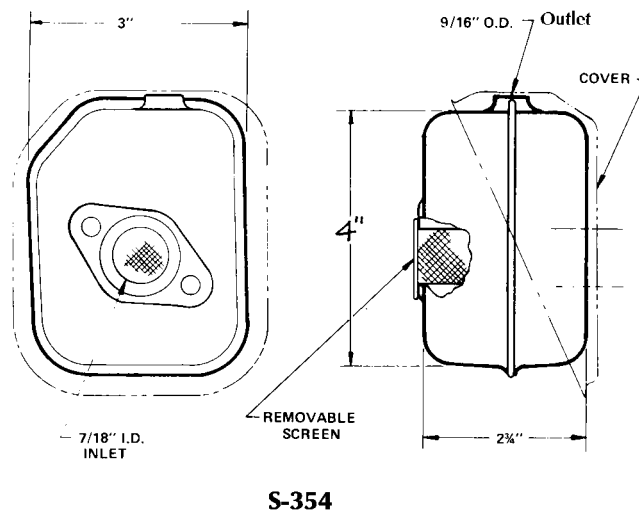
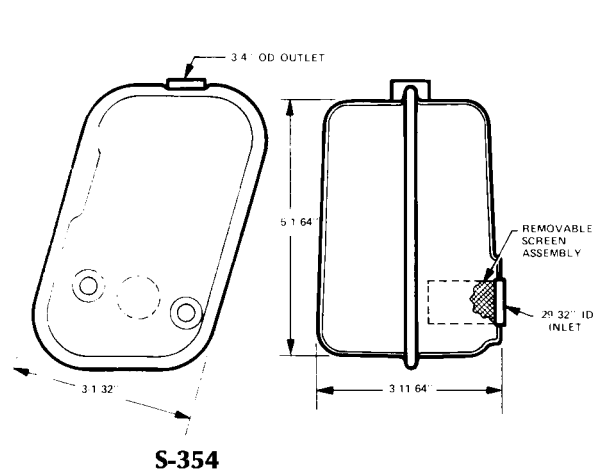

HONDA

HONDA (continued)

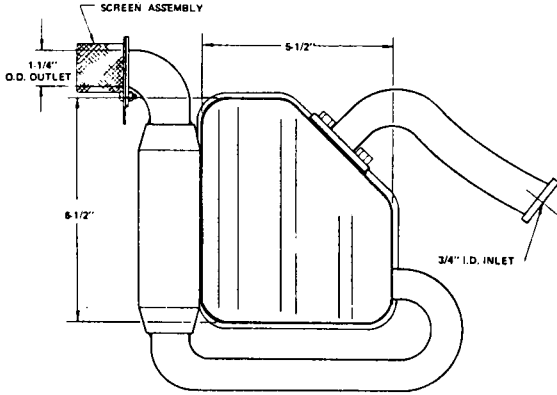

S-356A

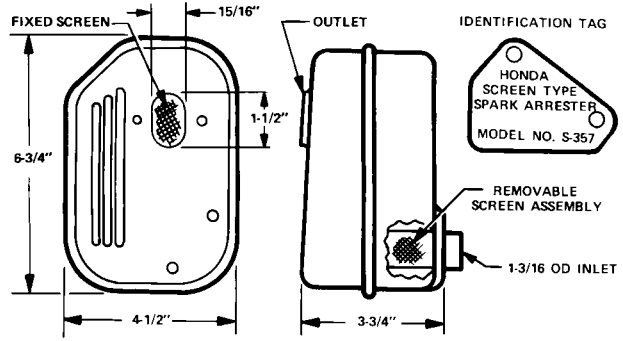

S-357

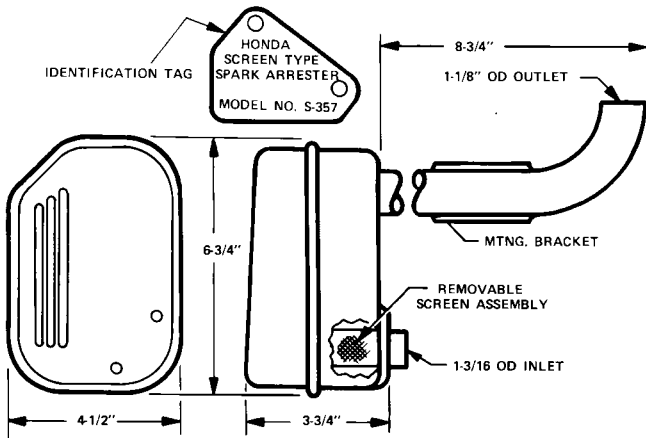

S-357

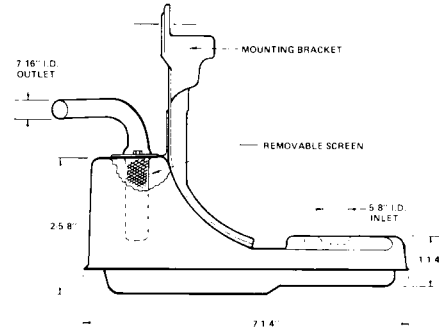

S-358

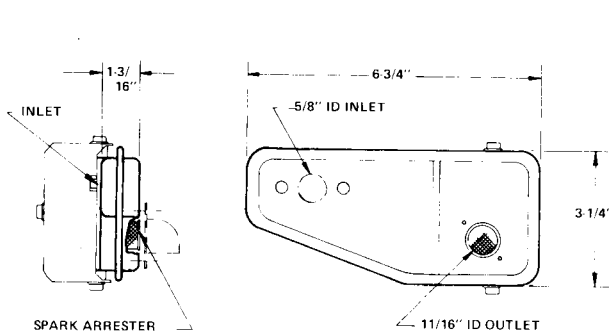

S-358

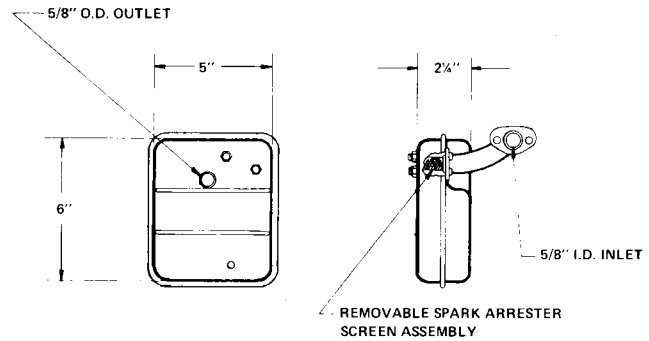

S-358

HONDA (continued)

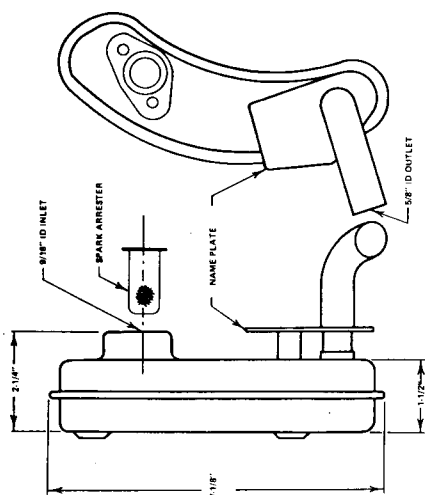

S-358

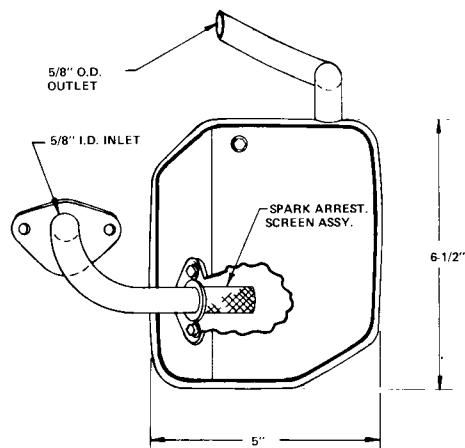

S-358

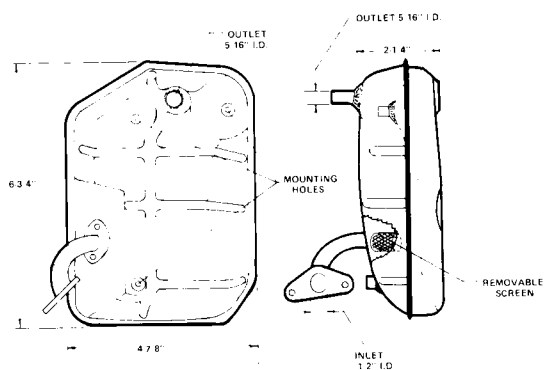

S-358

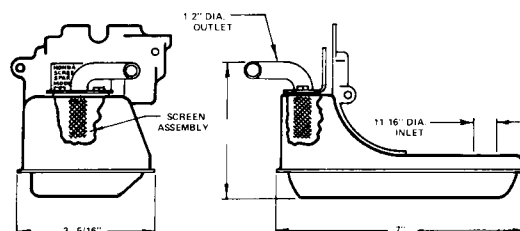

S-358

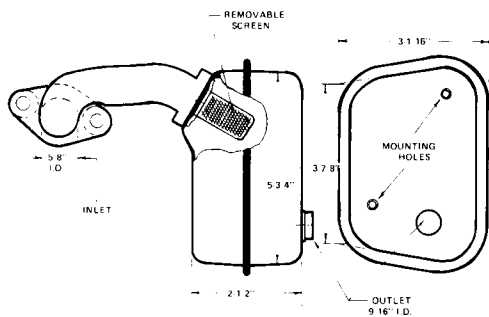

S-358

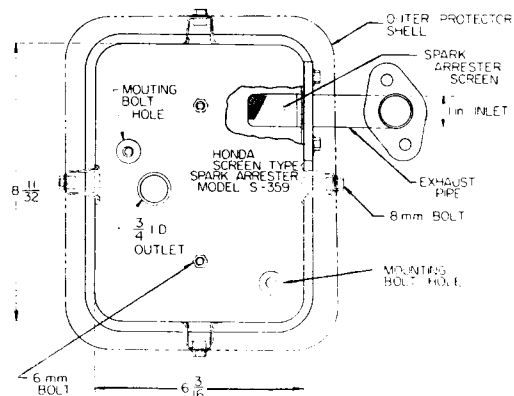

S-359

HONDA

HONDA (continued)

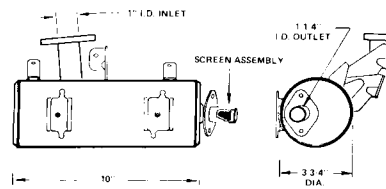
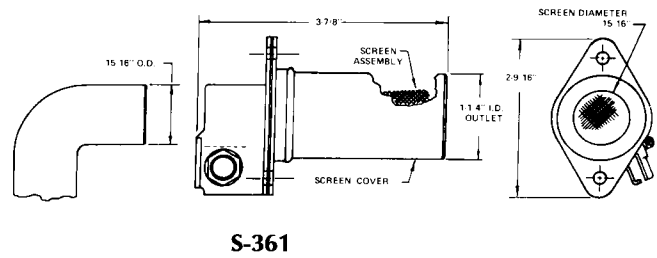
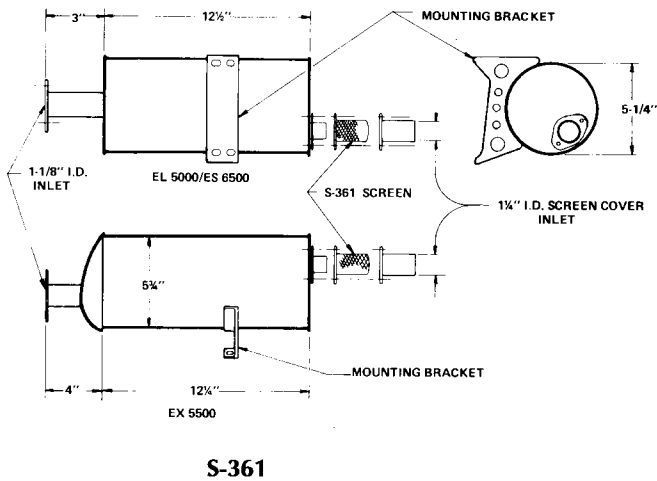
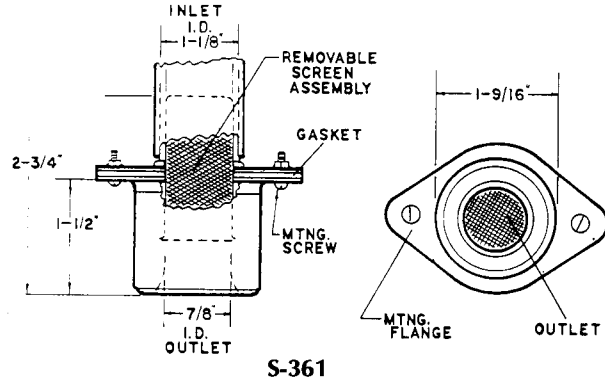
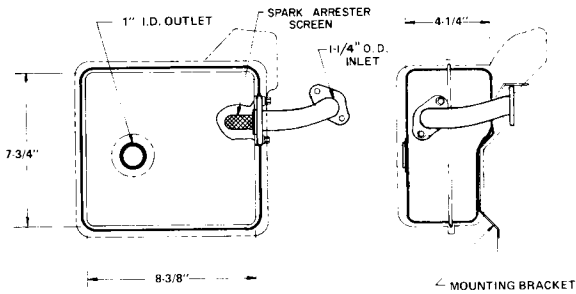
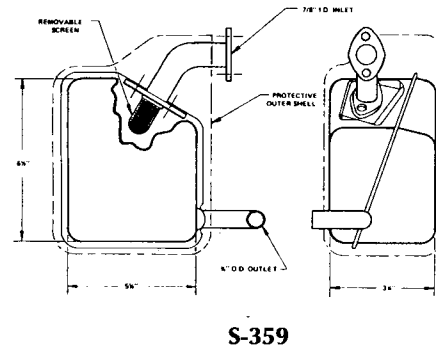
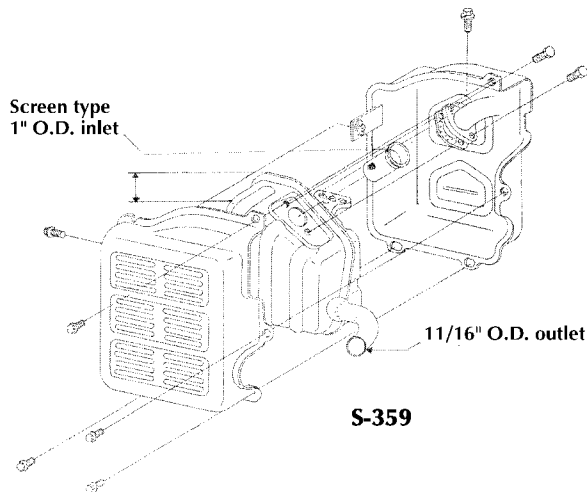

HONDA (continued)

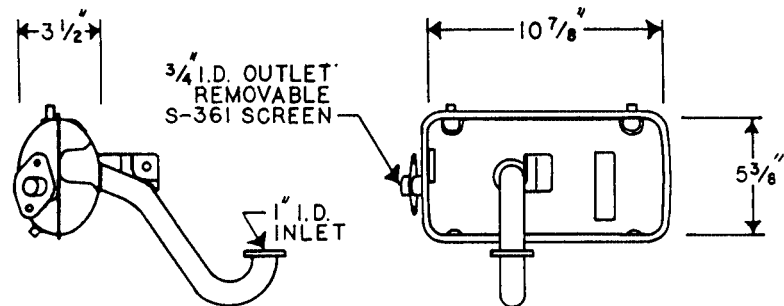

**S-361
H-4013**

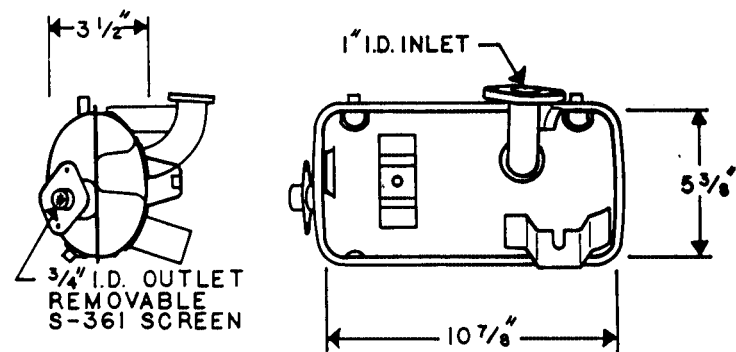

**S-361
H-4514**

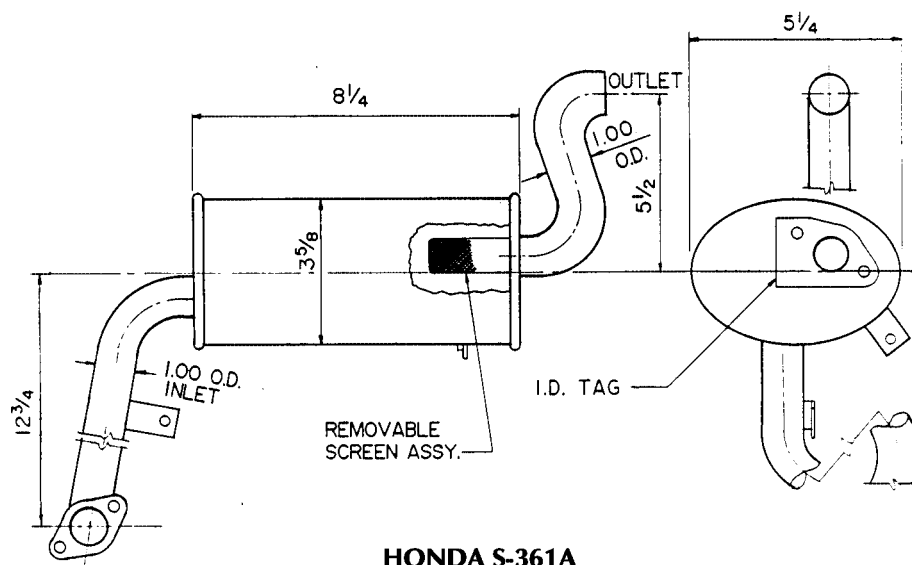

HONDA S-361A

HONDA

HONDA (continued)

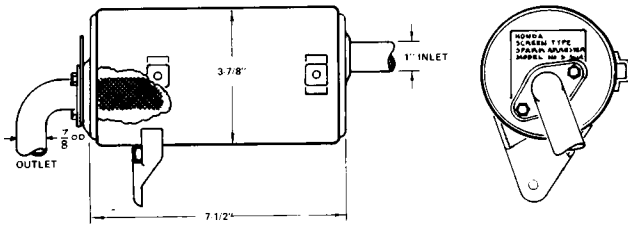

S-361A

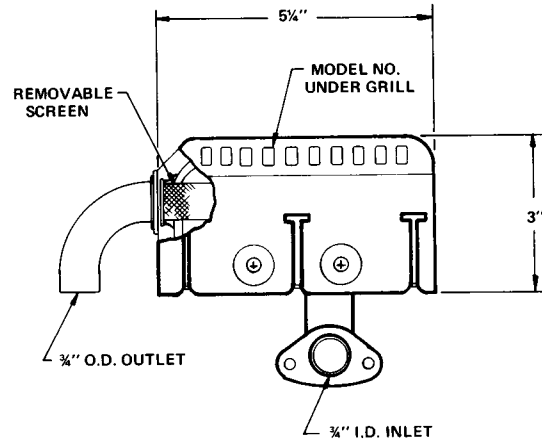

S-362

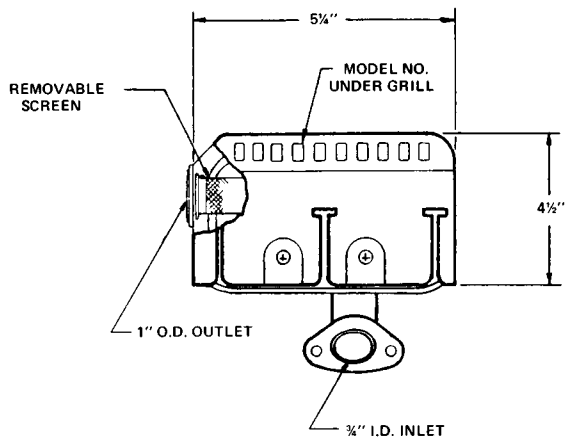

S-363

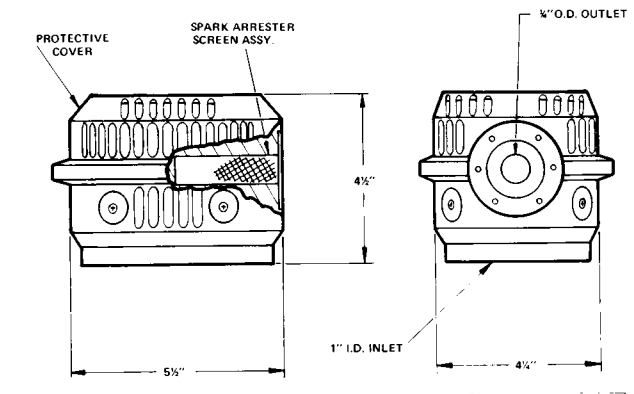

S-364

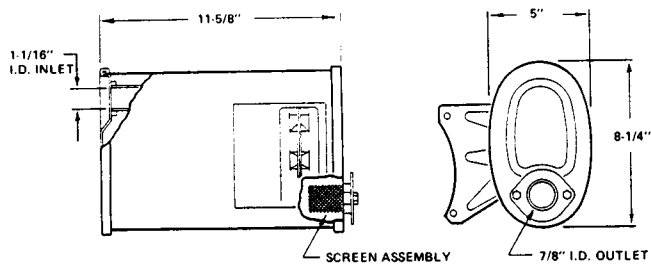

S-365

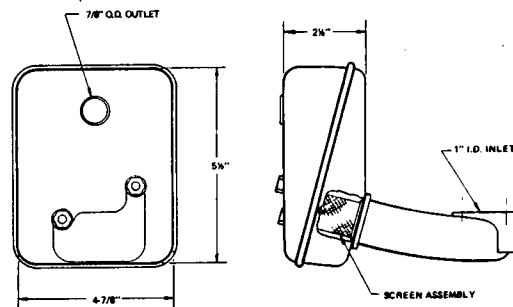

S-365